

## INSTALLATION & MAINTENANCE GUIDE

**AMP**<sup>®</sup> Lighting

AMP<sup>®</sup> Low Voltage Landscape Lighting

AMP<sup>®</sup> ForesterPro Downlight

AAL-1015-40-B-BZ

Help Hotline:

1-813-978-3900 • Mon-Fri 9am-6pm (EST)

[www.amplighting.com](http://www.amplighting.com)



**! Important Safety Instructions: Read Before Installation**

This luminaire is intended for installation in accordance with local codes and the National Electric Code (NEC). Failure to adhere to these codes and instructions may result in serious injury, property damage and void the warranty.

These instructions do not intend to cover all variations in installation, operation maintenance or mounting situations.

1. Make sure the power is turned OFF before installing or servicing this luminaire.
2. WARNING: risk of electrical shock. Install all luminaires 10 feet (3.05M) or more from pool, spa or fountain.
3. This luminaire is intended to be used only with a power supply (transformer) rated maximum of 300 watts (25 AMPS) at 15 volts.
4. Wiring connections must be made with wire connectors that are suitable for outdoor use.
5. Position the low voltage wire and wire connector so that it is located within 6 inches (15.2 cm) from a building structure, a luminaire or fitting.
6. The main low voltage cable is intended for shallow burial - less than 6 inches (152 mm).
7. If additional lengths of low voltage cable are required, please contact [www.amplighting.com](http://www.amplighting.com) or call 1-813-978-3900.

**! Important Safety Instructions**

**INSTRUCTIONS PERTAINING TO A RISK OF FIRE, OR INJURY TO PERSONS**  
**Lighted lamp is HOT!**

WARNING - To reduce the risk of FIRE OR INJURY TO PERSONS.

1. Turn off/unplug and allow to cool before replacing lamp.
2. Lamp gets HOT quickly! Contact only switch/plug when turning on.
3. Do not touch the hot lens, guard or enclosure.
4. Keep lamp away from materials that may burn.
5. Do not touch lamp at any time. Use a soft cloth. Oil from skin may damage lamp.
6. Do not operate the luminaire fitting with a missing or damaged shield.

SAVE THESE INSTRUCTIONS

## Package Contents

- A. (1) Fixture
- B. (3) Screws

- C. (3) Spacers

## Product Dimensions

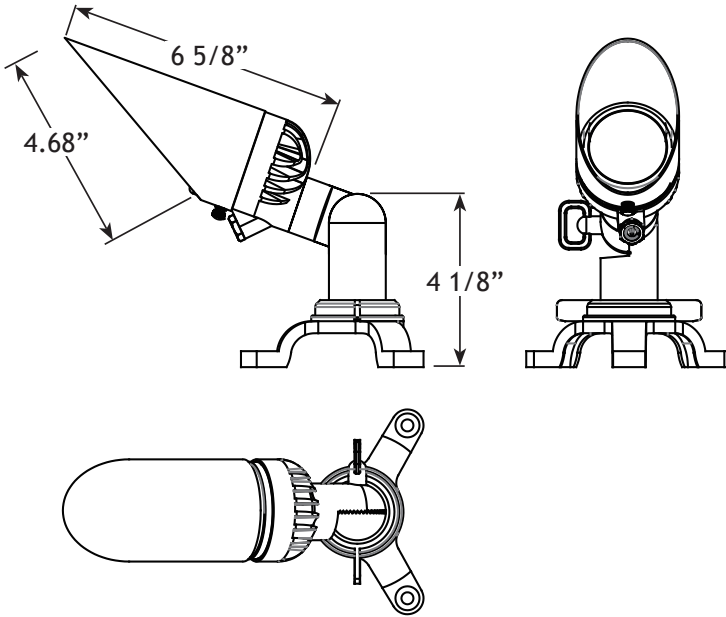

## 1 Install Fixture

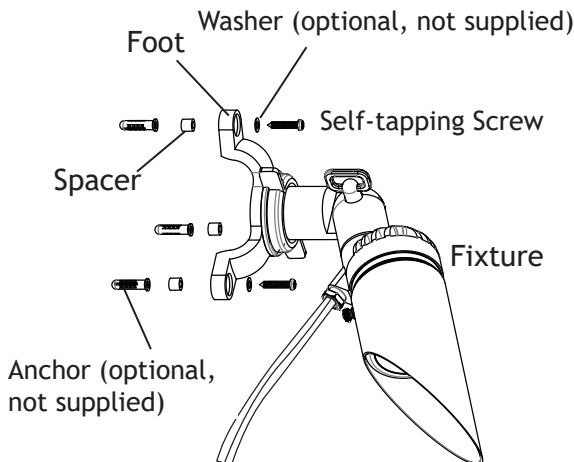

Determine the desired location for the fixture. Place the washers onto the self-tapping screws. Pass the self-tapping screws through the holes of the feet of fixture and spacers. Thread the self-tapping screws into the desired location to secure the fixture.

**NOTE:** Anchors are required for brick walls or concrete walls. To determine the locations for the anchors place the feet of the fixture onto your desired location and mark points from the holes of the feet.

# AMP<sup>®</sup> ForesterPro Downlight AAL-1015-40-B-BZ

## 2 Wire Connections

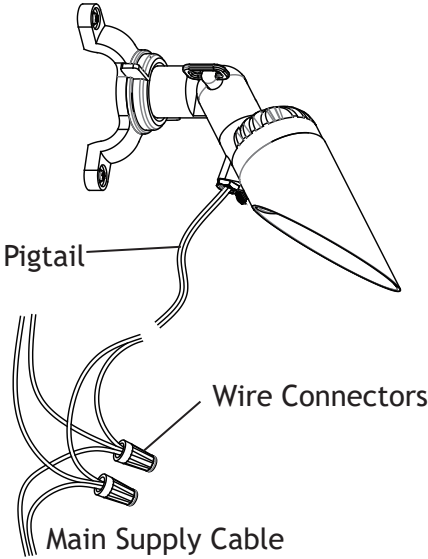

Strip both leads from the luminaire pigtail. Using two wire connectors (sold separately), connect the leads from the luminaire to the main supply cable leads.

## 3 Adjust Glare Guard Direction

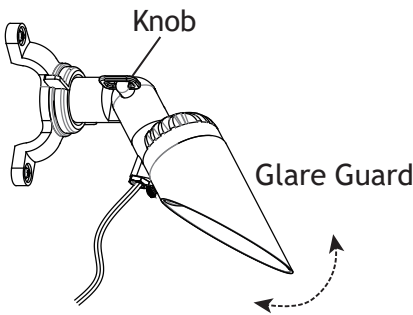

Loosen the knob and rotate the glare guard to your desired direction. Hand tighten the knob once your desired direction is achieved.

Install/Replace Optic

**4** Remove Glare Guard

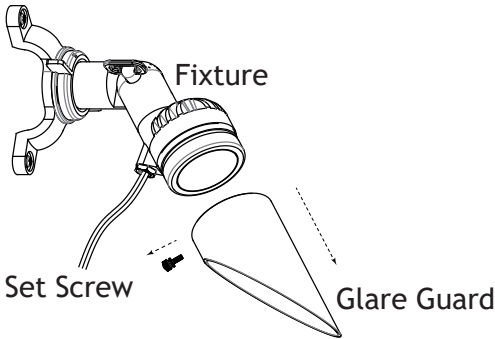

Loosen the set screw and remove the glare guard from the fixture.

**5** Remove Fixture Lens

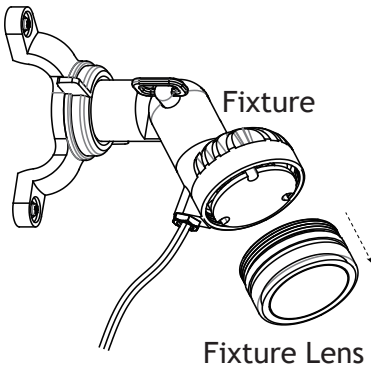

Turn the fixture lens counter-clockwise and remove it from the fixture.



**6** Replace Optic

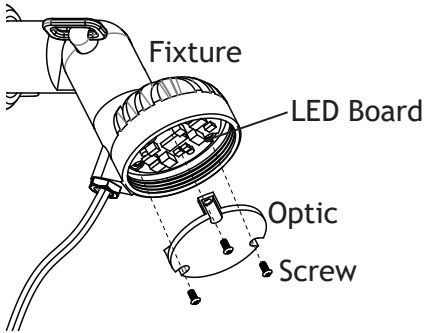

Loosen the screws, and remove the optic from the fixture.

Install the new optic in the fixture and reverse Step 6 - Step 4. Confirm the optic is properly aligned over the LED board before tightening down. Improper alignment when tightening the screws can cause the optic to break.



**AMP**<sup>®</sup> Lighting

**Help Hotline:**

**1-813-978-3900 • Mon-Fri 9am-6pm (EST)**

Specifications and product details subject to change without notice.  
© Copyright 2019, AMP<sup>®</sup> Lighting, Lutz FL USA 33549 • All rights reserved.  
customersupport@amplighting.com • 813.978.3900

**[www.amplighting.com](http://www.amplighting.com)**

IS-AAL-1015-40-B-BZ-ver2.pdf