

INSTALLATION & MAINTENANCE GUIDE

AMP[®] Lighting

AMP[®] Low Voltage Landscape Lighting

AMP[®] EscherPro MR16 Spotlight

AAL-1019-4-B-BZ

Help Hotline:

1-813-978-3900 • Mon-Fri 9am-6pm (EST)

www.amplighting.com



! Important Safety Instructions: Read Before Installation

This luminaire is intended for installation in accordance with local codes and the National Electric Code (NEC). Failure to adhere to these codes and instructions may result in serious injury, property damage and void the warranty.

These instructions do not intend to cover all variations in installation, operation maintenance or mounting situations.

1. Make sure the power is turned OFF before installing or servicing this luminaire.
2. **WARNING:** risk of electrical shock. Install all luminaires 10 feet (3.05M) or more from pool, spa or fountain.
3. This luminaire is intended to be used only with a power supply (transformer) rated maximum of 300 watts (25 AMPS) at 15 volts.
4. Wiring connections must be made with UL listed wire connectors that are suitable for outdoor use.
5. Position the low voltage wire and wire connector so that it is located within 6 inches (15.2 cm) from a building structure, a luminaire or fitting.
6. The main low voltage cable is intended for shallow burial - less than 6 inches (152 mm).
7. If additional lengths of low voltage cable are required, please contact www.amplighting.com or call 1-813-978-3900.

! Important Safety Instructions

INSTRUCTIONS PERTAINING TO A RISK OF FIRE, OR INJURY TO PERSONS
Lighted lamp is HOT!

WARNING - To reduce the risk of FIRE OR INJURY TO PERSONS.

1. Turn off/unplug and allow to cool before replacing lamp.
2. Lamp gets HOT quickly! Contact only switch/plug when turning on.
3. Do not touch the hot lens, guard or enclosure.
4. Keep lamp away from materials that may burn.
5. Do not touch lamp at any time. Use a soft cloth. Oil from skin may damage lamp.
6. Do not operate the luminaire fitting with a missing or damaged shield.

SAVE THESE INSTRUCTIONS

Package Contents

- A. (1) Fixture
- B. (1) Stake

Product Dimensions

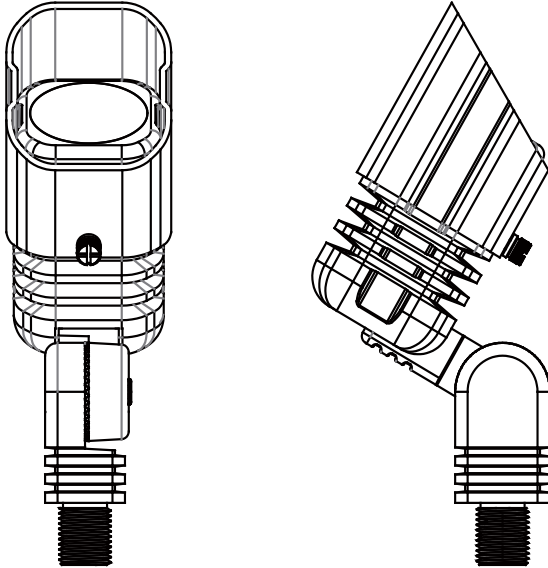

1 Install Stake

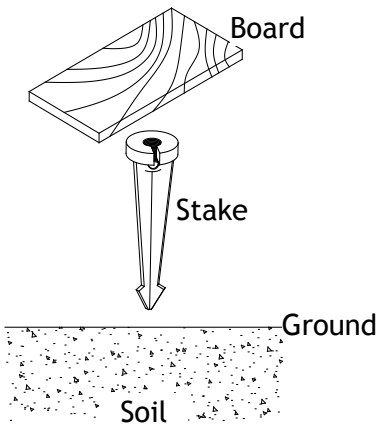

Determine the desired location for mounting the stake mount. Hammer the stake into the ground until flange of stake is flush to grade. To avoid damage to the stake, place a board on top of the stake while hammering.

Note: If the ground is hard and the stake is difficult to install, make a crosscut in the ground using a flat shovel.

AMP[®] EscherPro MR16 Spotlight AAL-1019-4-X-XX

2 Install Fixture to Stake

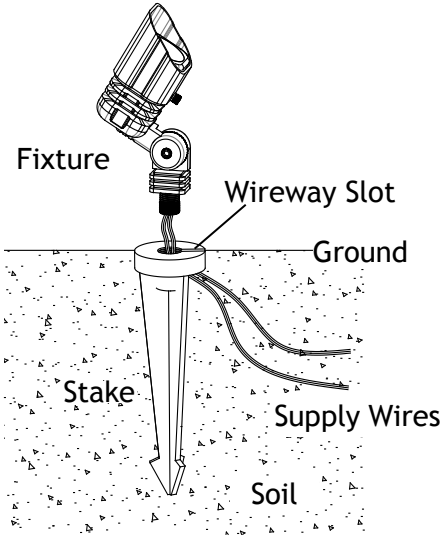

Clear away an area in the ground at the wireway slot on top of the stake. Lay the fixture pigtail into the wireway slot and attach the fixture onto the stake. Tighten until snug.

3 Wire Connection

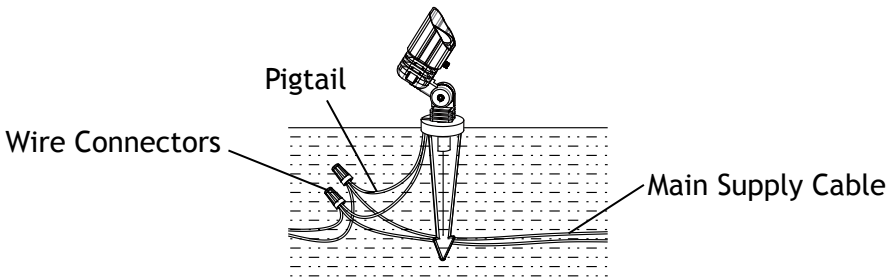

Strip both leads from the luminaire pigtail. Using two wire connectors (sold separately), connect the leads from the luminaire to the main supply cable leads.

AMP[®] AMP[®] EscherPro MR16 Spotlight AAL-1019-4-X-XX

4 Remove Glare Guard

Loosen the set screw and remove the glare guard from the fixture.

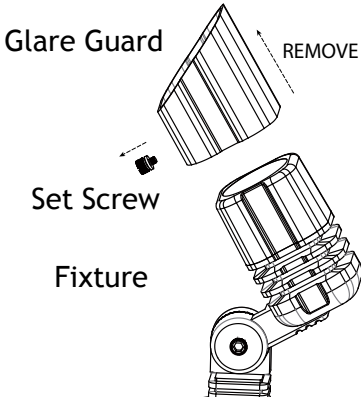

5 Remove Lens

Rotate the lens to remove it from the fixture.

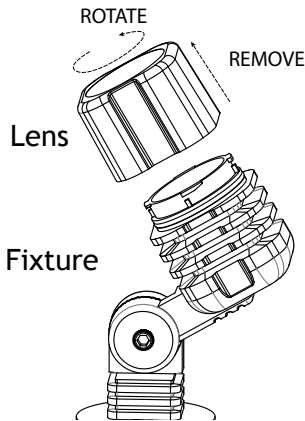



6 Install MR16 Bulb

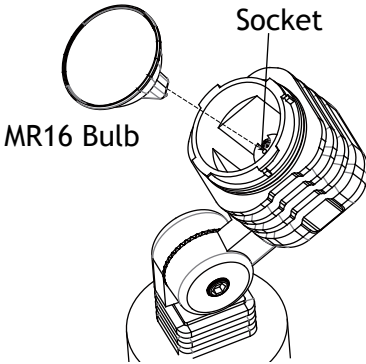

Insert MR16 bulb with the correct wattage and type marked on the fixture label.

CAUTION: Do not exceed maximum wattage marked on luminaire label.

7 Install MR16 Bulb

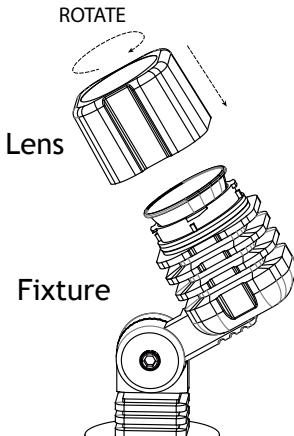

Place the lens back onto the fixture and rotate it until it is secured properly.

8 Install Glare Guard

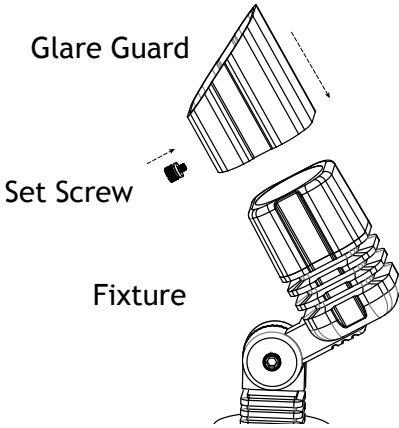

Install the glare guard back onto the fixture and secure with previously removed set screw.

9 Adjust Lamp Direction

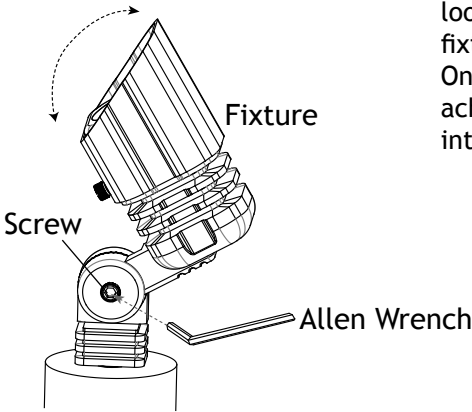

Using the provided Allen wrench, loosen the knuckle and adjust the fixture to your desired direction. Once your desired direction is achieved, tighten the knuckle into place.

Install/Replace Bulb

Remove the glare guard and the lens to expose the MR16 bulb and replace it with the correct wattage and type marked on the fixture label. Then, reinstall the lens and the glare guard.

IMPORTANT: MR16 bulb must be protected from moisture and dust at all times. Always reinstall the lens and the glare guard when removed.

AMP[®] Lighting

Help Hotline:

1-813-978-3900 • Mon-Fri 9am-6pm (EST)

Specifications and product details subject to change without notice.
© Copyright 2019, AMP[®] Lighting, Lutz FL USA 33549 • All rights reserved.
customersupport@amplighting.com • 813.978.3900

www.amplighting.com

IS-AAL-1019-4-B-BZ-ver1.pdf