

INSTALLATION & MAINTENANCE GUIDE

AMP[®] Lighting

AMP[®] Low Voltage Landscape Lighting

AMP[®] JoltPro Mini MR11 Spotlight (Lamp-Ready)

AAL-1043-B-BZ

Help Hotline:

1-813-978-3900 • Mon-Fri 9am-6pm (EST)

www.amplighting.com



Important Safety Instructions: Read Before Installation

This luminaire is intended for installation in accordance with local codes and the National Electric Code (NEC). Failure to adhere to these codes and instructions may result in serious injury, property damage and void the warranty.

These instructions do not intend to cover all variations in installation, operation maintenance or mounting situations.

1. Make sure that the power is turned OFF before installing or servicing this fixture.
2. Warning: this fixture is not intended to be installed within 10 feet [3 meters] of a pool, spa or fountain.
3. This fixture is intended to be used only with a power supply (transformer) rated maximum of 300 watts (25 AMPS) at 15 volts.
4. Underground Low Energy Cable must not be buried over 6" (15.2 cm) in order to connect to the main low voltage cable.
5. Wiring connections must be made with UL Listed wire connectors that are suitable for the application.
6. Position the wire connector so that it is located within 6 inches (15.2 cm) from a building structure, a luminaire, or fitting.

Important Safety Instructions

INSTRUCTIONS PERTAINING TO A RISK OF FIRE, OR INJURY TO PERSONS

Lighted lamp is HOT!

WARNING - To reduce the risk of FIRE OR INJURY TO PERSONS.

1. Turn off/unplug and allow to cool before reducing lamp.
2. Lamp gets HOT quickly!
3. Do not touch the hot lens, guard or cowl.
4. Keep lamp away from materials that may burn.
5. Do not touch lamp at any time.
6. Use a soft cloth.
7. Oil from skin may damage lamp.
8. Do not operate the fixture with a damaged or missing lens or shield.

Package Contents

A. (1) Fixture Body

Product Dimensions

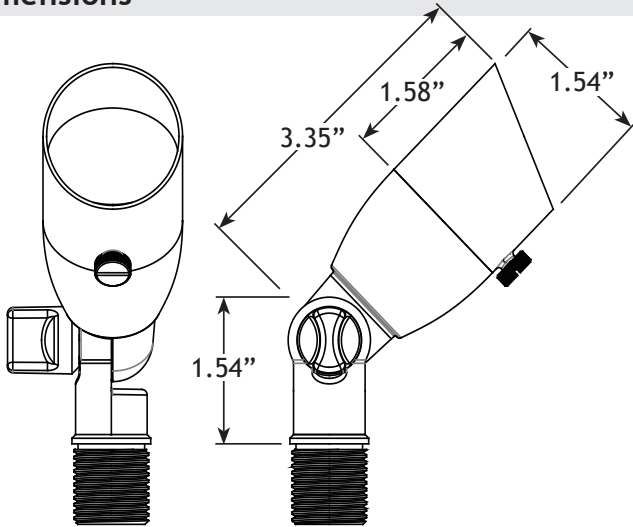

1 Install Stake

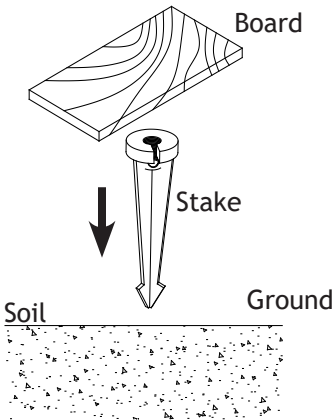

Determine the desired location for mounting the stake mount. Hammer the stake into the ground until flange of stake is flush to grade. To avoid damage to the stake, place a board on top of the stake while hammering.

Note: If the ground is hard and the stake is difficult to install, make a crosscut in the ground using a flat shovel.

2 Install Fixture Body to Stake

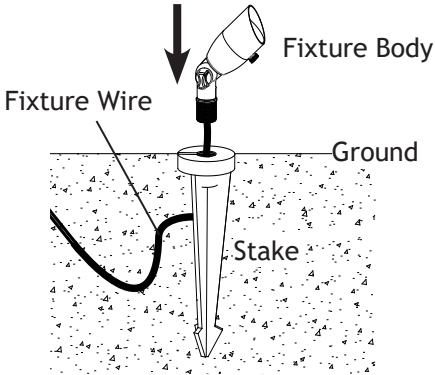

Pass the fixture wire through the center hole of the stake. Thread the fixture body onto the stake and hand tighten until snug.

3 Wire Connections

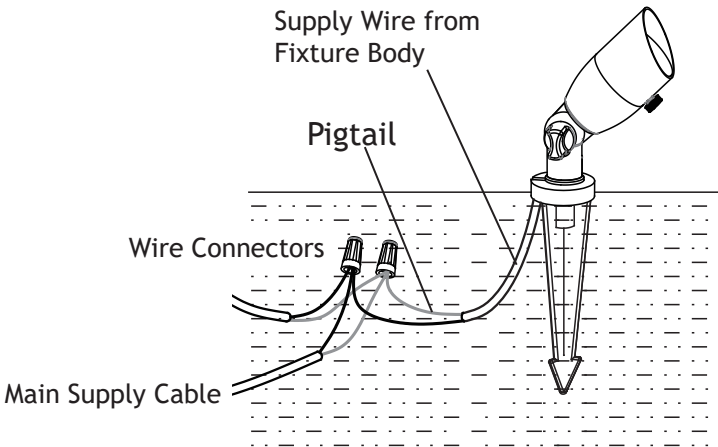

Strip both leads from the fixture body. Using two wire connectors (sold separately), connect the leads from the fixture body to the main supply cable leads.

4 Remove Glare Guard

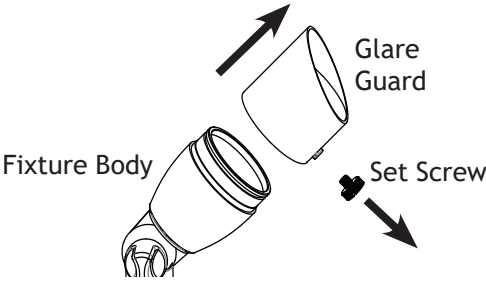

Loosen the set screw to remove the glare guard from the fixture body.

5 Install MR11 Bulb

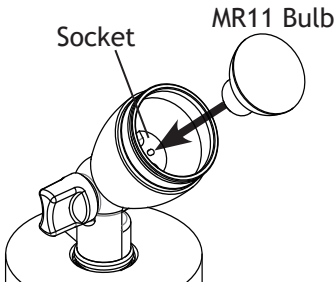

Insert MR11 Bulb with the correct wattage and type marked on fixture label and secure into place.

CAUTION: Do not exceed maximum wattage marked on luminaire label.

6 Install Glare Guard

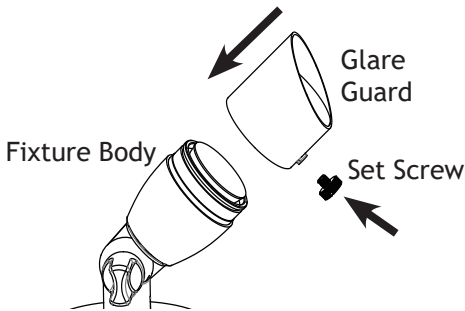

Place the glare guard back onto the fixture body and secure with the previously removed set screw. Hand tighten until snug.

INSTALLATION & MAINTENANCE GUIDE



AMP® JoltPro Mini MR11 Spotlight (Lamp-Ready)
AAL-1043-B-BZ

INSTALLATION & MAINTENANCE GUIDE



AMP® JoltPro Mini MR11 Spotlight (Lamp-Ready)
AAL-1043-B-BZ



Help Hotline:

1-813-978-3900 • Mon-Fri 9am-6pm (EST)

Specifications and product details subject to change without notice.
© Copyright 2022, AMP® Lighting, Lutz FL USA 33549 • All rights reserved.
customersupport@amplighting.com • 813.978.3900