

## INSTALLATION & MAINTENANCE GUIDE

**AMP<sup>®</sup>** Lighting

AMP<sup>®</sup> Low Voltage Landscape Lighting

AMP<sup>®</sup> NovellePro Path Light (Lamp - Ready)

APL-3012-B-BZ

**Help Hotline:**

1-813-978-3900 • Mon-Fri 9am-6pm (EST)

[www.amplighting.com](http://www.amplighting.com)

**! Important Safety Instructions: Read Before Installation**

This fixture is intended for installation in accordance with local codes and the National Electric Code (NEC). Failure to adhere to these codes and instructions may result in serious injury, property damage and void the warranty.

These instructions do not intend to cover all variations in installation, operation maintenance or mounting situation.

1. Make sure that the power is turned OFF before installing or servicing this fixture.
2. Warning: this fixture is not intended to be installed within 10 feet [3 meters] of a pool, spa or fountain.
3. This fixture is intended to be used only with a power supply (transformer) rated maximum of 300 watts (25 AMPS) at 15 volts.
4. Underground Low Energy Cable must not be buried over 6" (15.2 cm) in order to connect to the main low voltage cable.
5. Wiring connections must be made with UL Listed wire connectors that is suitable for outdoor use.
6. Position the wire connector so that it is located within 6 inches (15.2 cm) from a building structure, a luminaire, or fitting.

**! Important Safety Instructions: Read Before Installation**

**LIGHTED LAMP IS HOT!**

WARNING - TO REDUCE THE RISK OF FIRE OR INJURY TO PERSONS.

1. Turn off/unplug and allow to cool before reducing lamp.
2. Lamp gets HOT quickly!
3. Do not touch the hot lens, guard or cowl.
4. Keep lamp away from materials that may burn.
5. Do not touch lamp at any time.
6. Use a soft cloth.
7. Oil from skin may damage lamp.
8. Do not operate the fixture with a damaged or missing lens or shield.

## Package Contents

A. (1) Fixture

A. (1) Stake

## Parts Required

A. (1) LED Lamp (sold separately)

## Product Dimensions

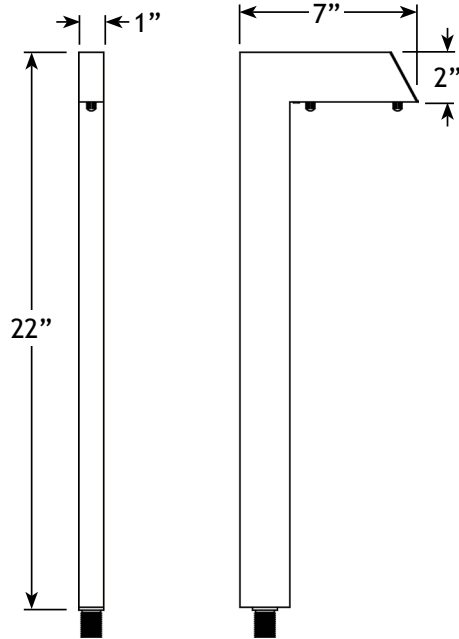

## 1 Install Stake

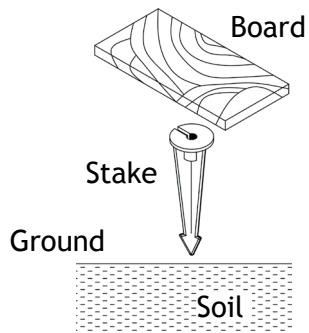

Determine the desired location for mounting the luminaire. Hammer the stake into the ground until flange of stake is flush to grade. To avoid damage to the stake, place a board on top of the stake while hammering.

NOTE: If the ground is hard and stake is difficult to install, make a crosscut in the ground using a flat shovel.

## INSTALLATION & MAINTENANCE GUIDE

**AMP**<sup>®</sup> AMP<sup>®</sup> NovellePro Path Light (Lamp - Ready)  
APL-3012-B-BZ

## 2 Remove Diffuser from Fixture

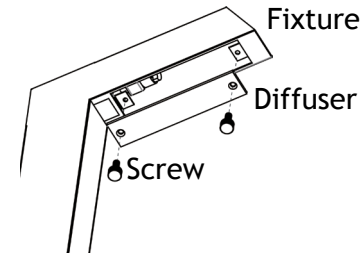

Remove the diffuser from the fixture by unthreading the screws.

## 3 Install Bulb

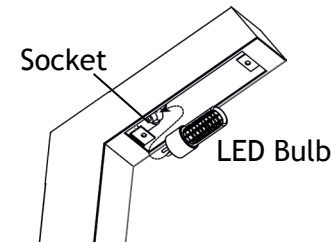

Insert the bulb with the correct wattage and type marked on the fixture label.

CAUTION: Do not exceed maximum wattage marked on luminaire label.

NOTE: DO NOT touch bulb with bare hands. Use soft cloth to handle bulb.

## 4 Install Diffuser to Fixture

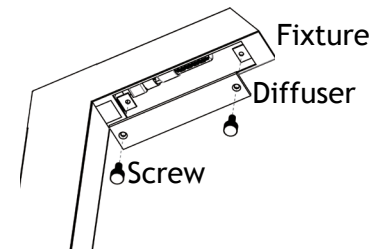

Attach the diffuser back onto the fixture and secure with screws. Tighten until snug.

## 5 Install Fixture to Stake

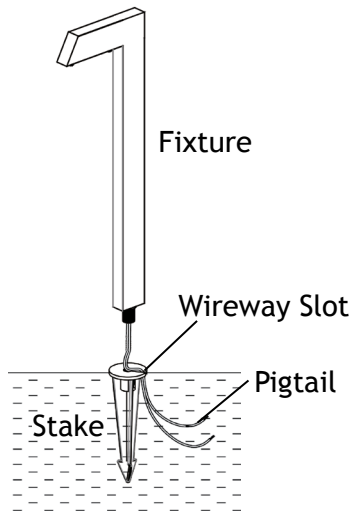

Clear away an area in the ground at the wireway slot on top of the stake. Lay the luminaire pigtail into the wireway slot and screw the stem onto the stake. If the assembly does not look straight, adjust by pushing or pulling on the stake only. Use a bubble level against the side of the stem to make sure it is perpendicular to the ground.

## 6 Wire Connection

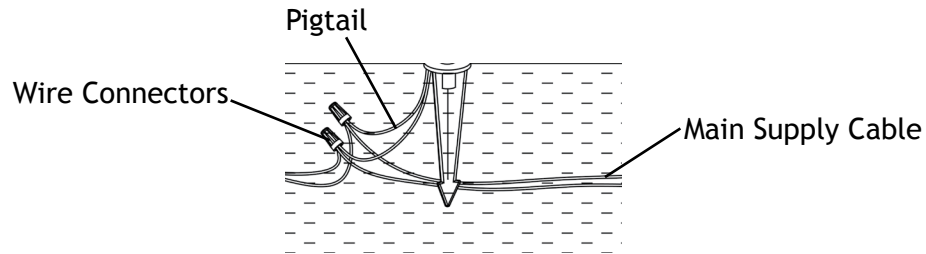

Strip both leads from the luminaire pigtail. Using two wire connectors (sold separately), connect the leads from the luminaire to the main low voltage supply cable leads.

## Install/Replace Bulb

Reverse Step 4 - Step 2 to expose the Bulb and replace it with correct wattage and type marked on fixture label. Reinstall Diffuser.

**IMPORTANT:** LED lamp must be protected from moisture and dust at all times. Always reinstall diffuser when moved.

**AMP**<sup>®</sup> Lighting

**Help Hotline:**

**1-813-978-3900 • Mon-Fri 9am-6pm (EST)**

Specifications and product details subject to change without notice.  
© Copyright 2019, AMP<sup>®</sup> Lighting, Lutz FL USA 33549 • All rights reserved.  
customersupport@amplighting.com • 813.978.3900

**[www.amplighting.com](http://www.amplighting.com)**