

INSTALLATION & MAINTENANCE GUIDE

AMP[®] Lighting

AMP[®] Low Voltage Landscape Lighting

AMP[®] Dual Mini PinnaclePro Path Light (Lamp - Ready)

APL-3015-B-BZ

Help Hotline:

1-813-978-3900 • Mon-Fri 9am-6pm (EST)

www.amplighting.com

INSTALLATION & MAINTENANCE GUIDE



AMP® Dual Mini PinnaclePro Path Light (Lamp Ready)
APL-3015-B-BZ

! Important Safety Instructions: Read Before Installation

This luminaire is intended for installation in accordance with local codes and the National Electric Code (NEC). Failure to adhere to these codes and instructions may result in serious injury, property damage and void the warranty.

These instructions do not intend to cover all variations in installation, operation maintenance or mounting situations.

1. Make sure that the power is turned OFF before installing or servicing this luminaire.
2. **WARNING:** risk of electrical shock. Install all luminaires 10 feet (3.05M) or more from pool, spa or fountain.
3. This luminaire is intended to be used only with a power supply (transformer) rated maximum of 300 watts (25 AMPS) at 15 volts.
4. Wiring connections must be made with UL Listed wire connectors that are suitable for outdoor use.
5. Position the low voltage wire and wire connector so that it is located within 6 inches (15.2 cm) from a building structure, a luminaire or fitting.
6. The main low voltage cable is intended for shallow burial - less than 6 inches (152 mm).

! Important Safety Instructions: Read Before Installation

INSTRUCTIONS PERTAINING TO A RISK OF FIRE, OR INJURY TO PERSONS
Lighted lamp is HOT!

WARNING - TO REDUCE THE RISK OF FIRE OR INJURY TO PERSONS.

1. Turn off/unplug and allow to cool before replacing lamp.
2. Lamp gets HOT quickly! Contact only switch/plug when turning on.
3. Do not touch the hot lens, guard or enclosure.
4. Keep lamp away from materials that may burn.
5. Do not touch lamp at any time. Use a soft cloth. Oil from skin may damage lamp.
6. Do not operate the luminaire fitting with a missing or damaged shield.

SAVE THESE INSTRUCTIONS

Package Contents

- A. (1) Fixture Body
- B. (2) Stake

Parts Required

- A. (2) MR11 Lamps
- B. (1) Stake Cover (optional)

Product Dimensions

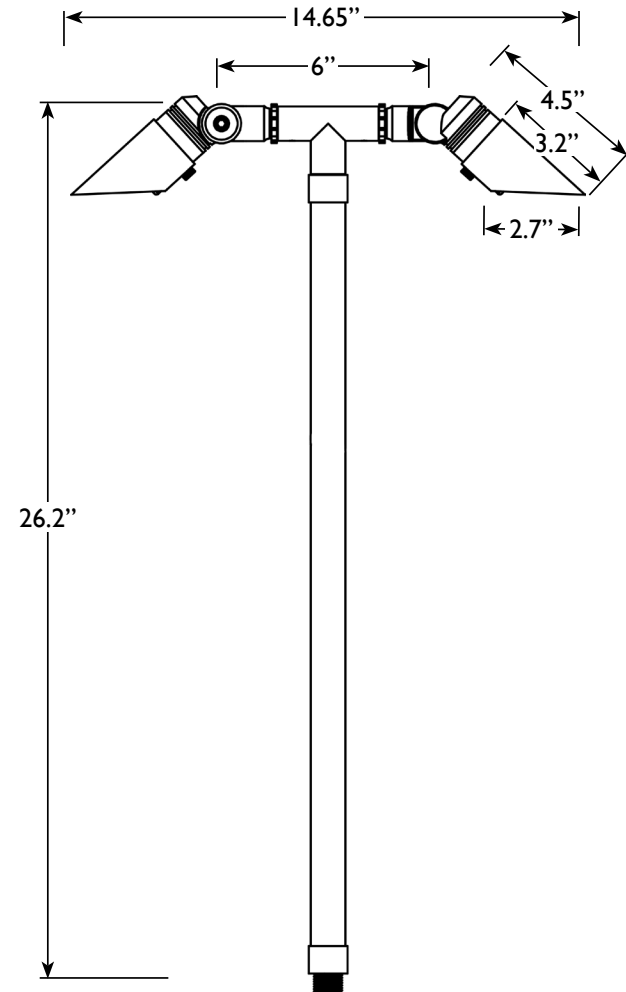

1 Install Stake

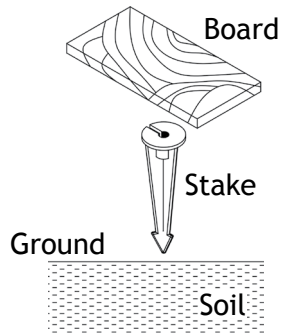

Determine the desired location for mounting the fixture. Hammer the stake into the ground until flange of stake is flush to grade. To avoid damage to the stake, place a board on top of the stake while hammering.

NOTE: If the ground is hard and the stake is difficult to install, make a crosscut in the ground using a flat shovel.

2 Remove Shield and Glare Guard

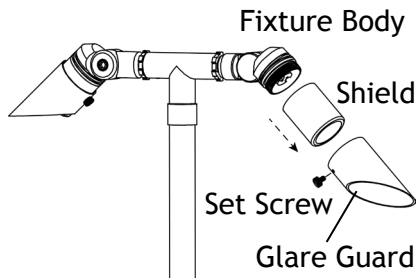

Loosen the set screw and remove the glare guard from the shield. Remove the shield from the fixture.

3 Install Lamp

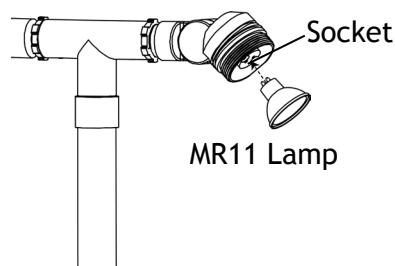

Insert the lamp with the correct wattage and type marked on the fixture label.

CAUTION: Do not exceed maximum wattage marked on luminaire label.

NOTE: DO NOT touch lamp with bare hands. Use soft cloth to handle lamp.

4 Install Shield and Glare Guard

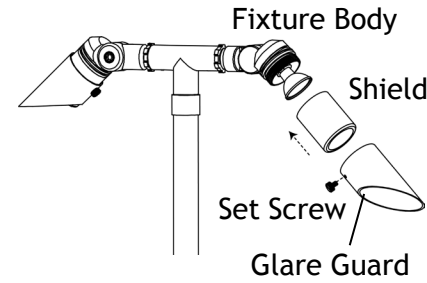

Place the shield over the lamp and thread onto the fixture. Attach the glare guard back onto the shield and secure with the set screw. Tighten until snug.

5 Install Fixture to Stake

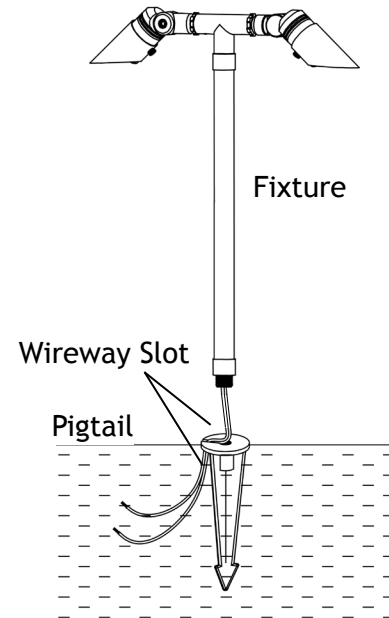

Clear away an area in the ground at the wireway slot on top of the stake. Align the wireway slot of the stake cover and the stake. Lay the luminaire pigtail into the wireway slot and attach the fixture onto the stake.

6 Wire Connections

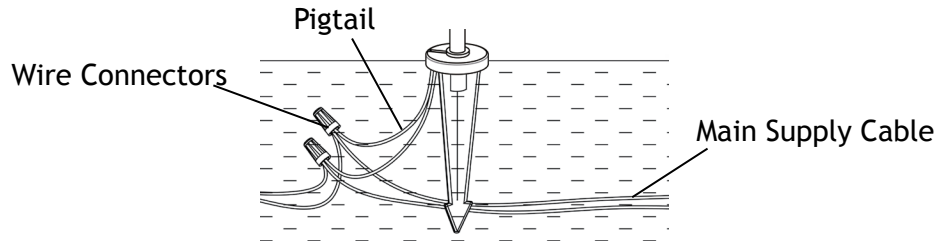

Strip both leads from the luminaire pigtail. Using two wire connectors (sold separately), connect the leads from the luminaire to the main supply cable leads.

7 Adjust Angle of Fixture Body

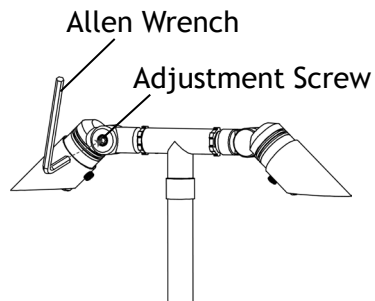

Using an Allen Wrench, loosen the adjustment screws and modify the fixture bodies to the desired angles. Then tighten the adjustment screws.

Install/Replace Lamp

Loosen the set screw on glare guard, remove the glare guard and the shield to expose the lamp. Replace it with the correct wattage and type marked on the fixture label. Then reinstall the shield and glare guard and tighten with the set screw.

IMPORTANT: Halogen lamps must be protected from moisture and dust at all times. Always reinstall the shield and glare guard when moved.

INSTALLATION & MAINTENANCE GUIDE

AMP[®] Lighting

AMP[®] Low Voltage Landscape Lighting

AMP[®] Dual Mini PinnaclePro Path Light (Lamp - Ready)

APL-3015-B-BZ

Help Hotline:

1-813-978-3900 • Mon-Fri 9am-6pm (EST)

www.amplighting.com