

INSTALLATION & MAINTENANCE GUIDE

AMP[®] Lighting

AMP[®] Low Voltage Landscape Lighting

AMP[®] Solar LED Post-Top Light

ASPL-3029-B-BZ & ASPL-3029-P-BK

Help Hotline:

1-813-978-3900 • Mon-Fri 9am-6pm (EST)

www.amplighting.com



AMP® Solar LED Post-Top Light
ASPL-3029-B-BZ & ASPL-3029- P-BK



Important Safety Instructions: Read Before Installation

This luminaire is intended for installation in accordance with local codes and the National Electric Code (NEC). Failure to adhere to these codes and instructions may result in serious injury, property damage and void the warranty.

These instructions do not intend to cover all variations in installation, operation maintenance or mounting situations.

Please note that these solar fixtures are equipped with built-in photocells, so they will not turn on until it is dark enough. These fixtures will also require plenty of sunlight to function properly. It's best to have the fixture in an area where the sun will get to it at all times throughout the day and where no ambient lighting will affect the photocell at night. If your fixture is not functioning at night, be sure that the on/off button has been engaged. See step one for details.



Important Safety Instructions

INSTRUCTIONS PERTAINING TO A RISK OF FIRE, OR INJURY TO PERSONS

Lighted lamp is HOT!

WARNING - To reduce the risk of FIRE OR INJURY TO PERSONS.

1. Lamp gets HOT quickly!
2. Do not touch the hot lens, guard or enclosure.
3. Keep lamp away from materials that may burn.
4. Do not touch lamp at any time. Use a soft cloth. Oil from skin may damage lamp.
5. Do not operate the luminaire fitting with a missing or damaged shield.

SAVE THESE INSTRUCTIONS

Package Contents

- A. (1) Fixture Body
- B. (4) Self-tapping Screws

Product Dimensions

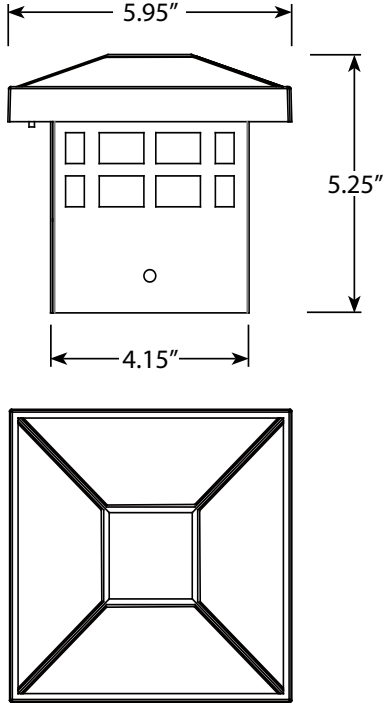



1 Test Solar Light

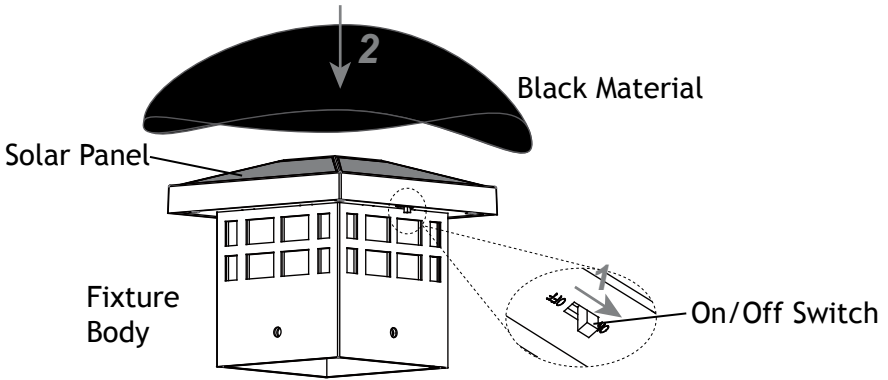

Slide the ON/OFF switch of the fixture to the “ON” position. Cover solar panels completely by using a dark material. The fixture will light up when the solar panel is covered and turn off when it is uncovered.

Now you can proceed to the next steps of installation knowing the fixture is ON.

2 Install Fixture to Post

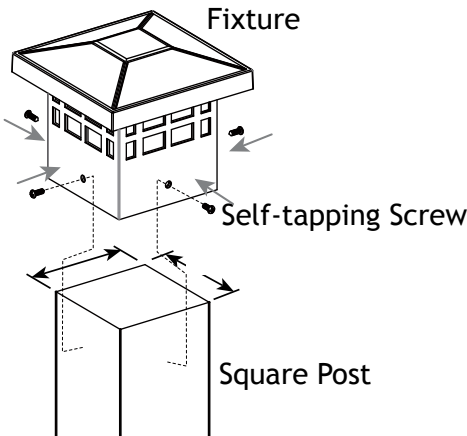

Attach the fixture onto a 4”x 4” square wood post and secure with self-tapping screws. Tighten with a screwdriver.

How to Replace Battery

3 Remove Solar Panel

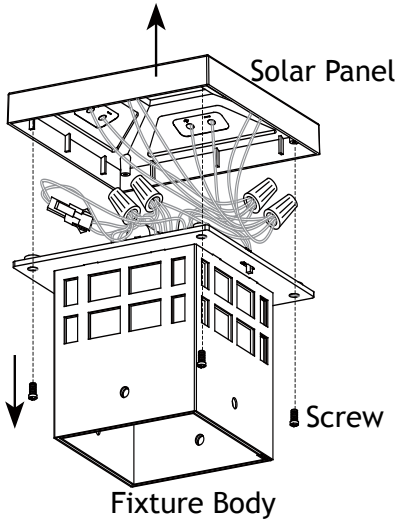

Using a screw driver, remove the screws from the corners to remove the solar panel from the fixture body.

4 Replace Battery

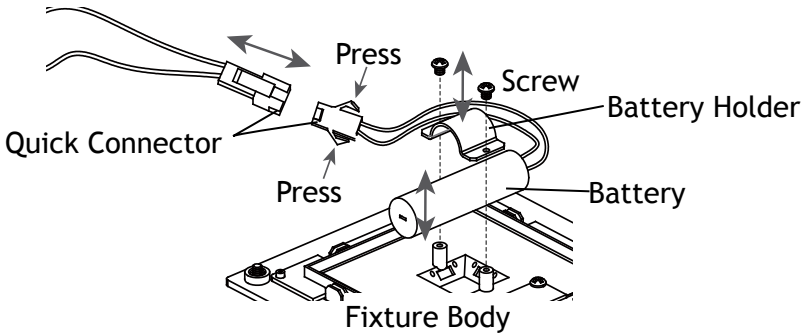

Disconnect the quick connector by pressing the tabs on the side. Remove the old battery by removing the two screws. Replace the battery and secure it with the previously removed screws. Then connect the tabs of the quick connector back together.

Reinstall the solar panel to the fixture body and secure with previously removed screws.



AMP® Solar LED Post-Top Light
ASPL-3029-B-BZ & ASPL-3029- P-BK

INSTALLATION & MAINTENANCE GUIDE



AMP® Solar LED Post-Top Light
ASPL-3029-B-BZ & ASPL-3029- P-BK

AMP[®] Lighting

Help Hotline:

1-813-978-3900 • Mon-Fri 9am-6pm (EST)

Specifications and product details subject to change without notice.
© Copyright 2021, AMP[®] Lighting, Lutz FL USA 33549 • All rights reserved.
customersupport@amplighting.com • 813.978.3900

www.amplighting.com

IS-ASPL-3029-ver3.pdf