

## INSTALLATION & MAINTENANCE GUIDE

**AMP<sup>®</sup>** Lighting

AMP<sup>®</sup> Solar Landscape Lighting

AMP<sup>®</sup> Solar Bistro Lights (50ft)

ASSI-9008-50-BK

Help Hotline:

1-813-978-3900 • Mon-Fri 9am-6pm (EST)

[www.amplighting.com](http://www.amplighting.com)



## Important Safety Instructions: Read Before Installation

This luminaire is intended for installation in accordance with local codes and the National Electric Code (NEC). Failure to adhere to these codes and instructions may result in serious injury, property damage and void the warranty.

These instructions do not intend to cover all variations in installation, operation maintenance or mounting situations.

Please note that these solar fixtures are equipped with built-in photocells, so they will not turn on until it is dark enough. These fixtures will also require plenty of sunlight to function properly. It's best to place the fixture in an area where the sun will get to it through out the day and where no ambient lighting will affect the photocell at night. If your fixture is not functioning at night, be sure that the on/off button has been engaged. See step one for details.



## Important Safety Instructions

### INSTRUCTIONS PERTAINING TO A RISK OF FIRE, OR INJURY TO PERSONS Lighted lamp is HOT!

WARNING - To reduce the risk of FIRE OR INJURY TO PERSONS.

1. Lamp gets HOT quickly!
2. Do not touch the hot lens, guard or enclosure.
3. Keep lamp away from materials that may burn.
4. Do not touch lamp at any time. Use a soft cloth. Oil from skin may damage lamp.
5. Do not operate the luminaire fitting with a missing or damaged shield.

SAVE THESE INSTRUCTIONS

## Package Contents

- A. (1) Solar Panel
- B. (1) Support Arm
- C. (1) Clamp with Support Arm
- D. (1) Bistro String (50 feet long)
- E. (32) Bulbs (2 replacement bulbs are included)
- F. (1) Stake
- G. (4) Straps
- H. (4) Screws
- I. (4) Wall Anchors

## Parts Sold Separately

- A. (1) Guide Wire

## Product Dimensions

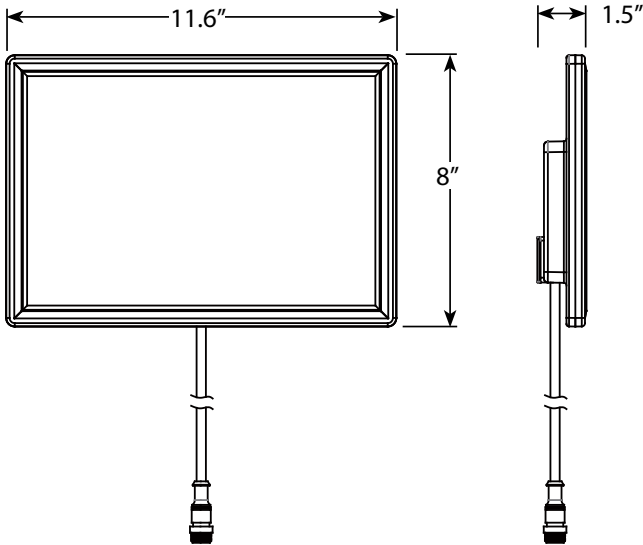

SOLAR PANEL

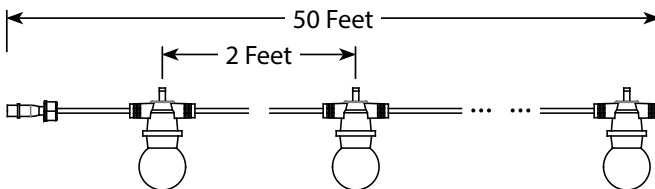

BISTRO STRING

Follow 1 of the 4 Solar Panel Mounting Methods

## Method 1: Clamp Mount

### 1 Mount Clamp with Support Arm

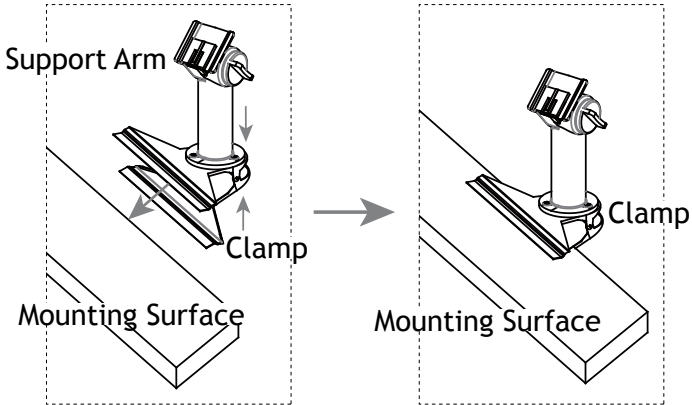

Attach the clamp onto the side of the mounting surface.

Then go to the Installing Solar Panel and Bistro String steps.

# AMP® AMP® Solar Bistro Lights (50ft) ASSI-9008-50-BK

## Method 2: Surface Mount

### 1 Surface Mount

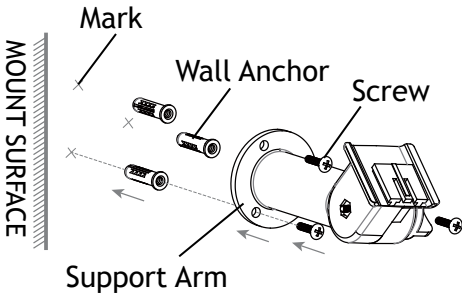

Place the support arm onto the surface and mark points using the holes as a guide. Then, drill proper holes for the wall anchors to be inserted.

Attach the support arm onto the surface using the screws. Make sure the screws are tightened with a screwdriver to secure the support arm.

Then go to the Installing Solar Panel and Bistro String steps.

# AMP® AMP® Solar Bistro Lights (50ft) ASSI-9008-50-BK

## Method 3: Strap Mount

### 1 Insert Straps

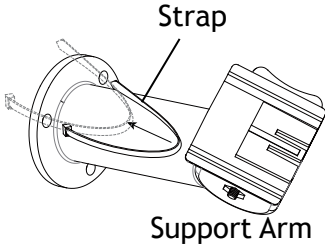

Pass the ends of the strap through two holes on the support arm.

### 2 Tie the Strap

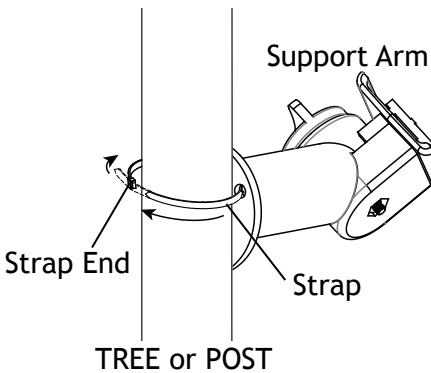

Install the support arm by wrapping the strap around the desired tree or post. Insert the pointed end of the strap into the opposite end of the strap and pull it through to tighten the support arm onto the tree or post.

Then go to the Installing Solar Panel and Bistro String steps.

# AMP<sup>®</sup> AMP<sup>®</sup> Solar Bistro Lights (50ft) ASSI-9008-50-BK

## Method 4: Stake Mount

### 1 Install Stake to Support Arm

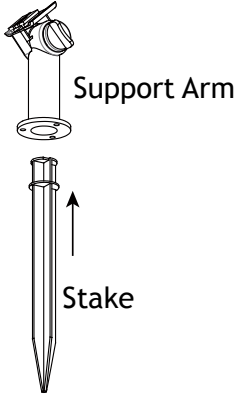

Insert the top end of the stake into the base of support arm.

### 2 Insert Stake to Ground

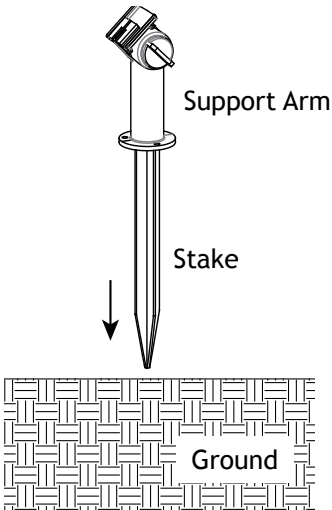

Insert the stake into the ground.

Then go to the Installing Solar Panel and Bistro String steps.

# AMP<sup>®</sup> AMP<sup>®</sup> Solar Bistro Lights (50ft) ASSI-9008-50-BK

## Install Solar Panel and Bistro String

### 1 Remove Wire Cover

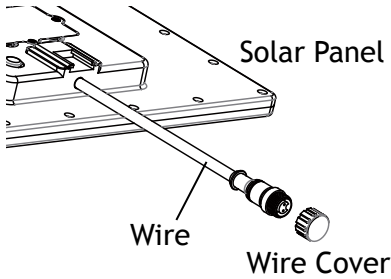

Twist and remove the wire cover from the solar panel.

### 2 Connect Wires

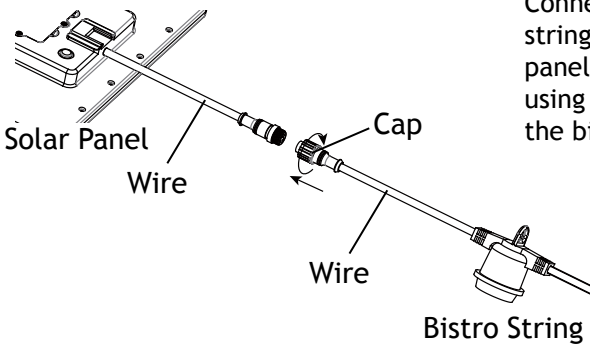

Connect the wire from bistro string to the wire from the solar panel. Tighten cords together by using the cap on the wire from the bistro string.

### 3 Install One Bulb to Test

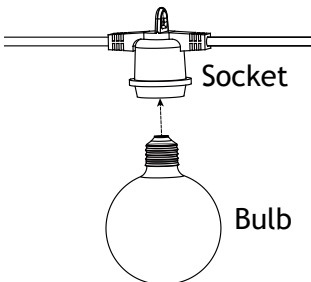

Thread one bulb onto one socket and tighten gently.





#### 4 Test Solar Panel

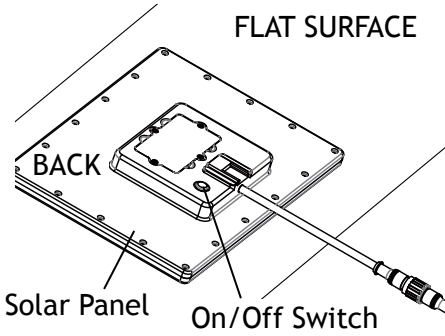

Place the solar panel onto a flat opaque working surface. Press the ON/OFF switch on the back of the solar panel to test the light source. The light will turn on while the switch is on.

Now you can proceed to next steps of installations knowing the fixture is in ON mode.

#### 5 Insert Stake to Ground

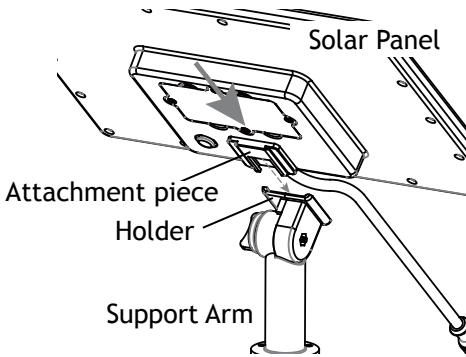

Insert the attachment piece on the back of the solar panel onto the holder on the top end of the support arm.

#### 6 Install Bistro String

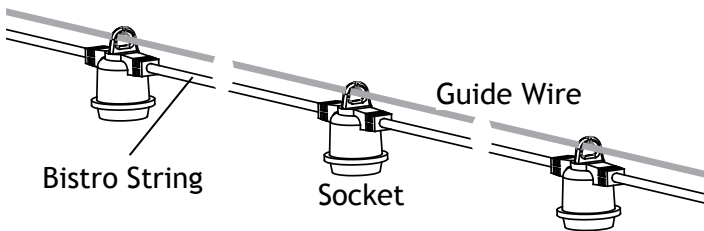

Pass the guide wire through the holes on the top end of the sockets and then fix the guide wire to your desired location or tie the bistro string to applicable locations directly.

## 7 Install Remaining Bulbs

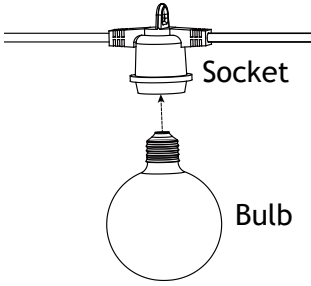

Thread bulbs onto the sockets and tighten gently.

## 8 Final Adjustment

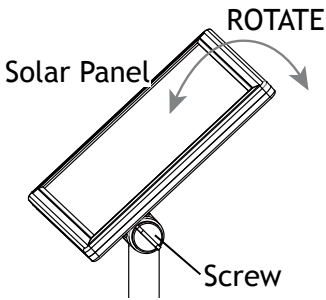

Loosen the screw at the knuckle to adjust the solar panel to make sure it can get plenty of sunlight. Then tighten the screw to secure the solar panel placement.

## How to Replace Battery

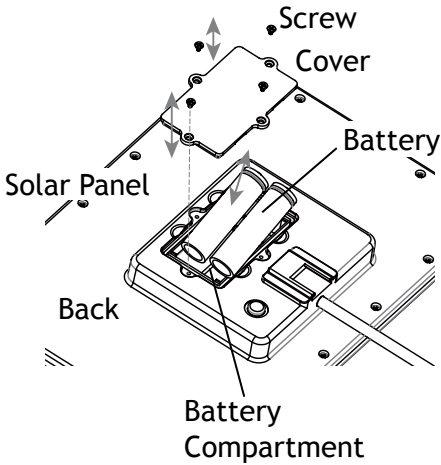

1. Using a screwdriver, remove the screws from the cover on the back of the solar panel.
2. Remove the cover.
3. Remove the battery out of the battery compartment and replace it with a new one.
4. Attach the cover back onto the solar panel and secure with previously removed screws.

**AMP**<sup>®</sup> Lighting

**Help Hotline:**

**1-813-978-3900 • Mon-Fri 9am-6pm (EST)**

Specifications and product details subject to change without notice.  
© Copyright 2021, AMP<sup>®</sup> Lighting, Lutz FL USA 33549 • All rights reserved.  
customersupport@amplighting.com • 813.978.3900

**[www.amplighting.com](http://www.amplighting.com)**

IS-ASSI-9008-50-BK-ver1.pdf