

INSTALLATION INSTRUCTIONS



VOLT® Low Voltage Landscape Lighting

VOLT® Solar Integrated LED Path Light

VSPL-1045-BBZ-R1 & VSPL-1045-PBK-R1

Help Hotline:

1-813-978-3700 • Mon-Fri 8am-8pm • Sat-Sun 10am - 6pm (EST)

Specifications and product details subject to change without notice.
© Copyright 2023, VOLT® Lighting, Lutz FL USA 33549 • All rights reserved.
customersupport@voltlighting.com • 813.978.3700



Important: Please Read Before Installation

This luminaire is intended for installation in accordance with local codes and the National Electric Code (NEC). Failure to adhere to these codes and instructions may result in serious injury, property damage and void the warranty.

These instructions do not intend to cover all variations in installation, operation maintenance or mounting situations.

Please note that these solar fixtures are equipped with built-in photocells, so they will not turn on until it is dark enough. These fixtures will also require plenty of sunlight to function properly. It's best to have the fixture in an area where the sun will get to it at all times throughout the day and where no ambient lighting will affect the photocell at night. If your fixture is not functioning at night, be sure that the on/off button has been engaged. See step one for details.

Important Safety Instructions

INSTRUCTIONS PERTAINING TO A RISK OF FIRE, OR INJURY TO PERSONS Lighted lamp is HOT!

WARNING - To reduce the risk of FIRE OR INJURY TO PERSONS.

1. Lamp gets HOT quickly!
2. Do not touch the hot lens, guard or enclosure.
3. Keep lamp away from materials that may burn.
4. Do not touch lamp at any time. Use a soft cloth. Oil from skin may damage lamp.
5. Do not operate the luminaire fitting with a missing or damaged shield.

SAVE THESE INSTRUCTIONS

Package Contents

- A. (1) Fixture Body
- B. (1) Battery

Parts Required

- A. (1) Mounting Accessory
- B. (1) Riser

Product Dimensions

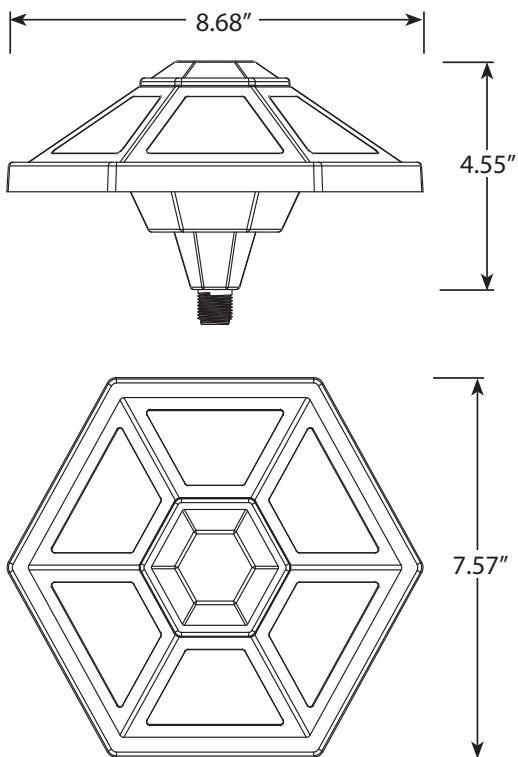



1 Remove Battery Compartment Cover

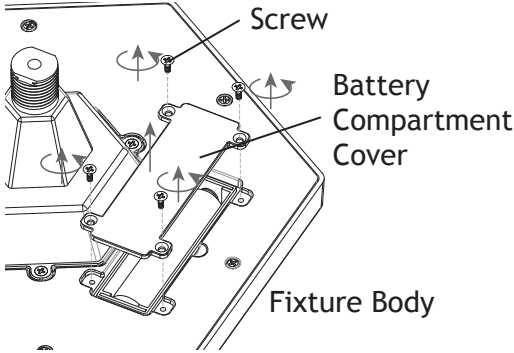

Using a screwdriver, remove the battery compartment cover from the fixture body.

2 Install Battery

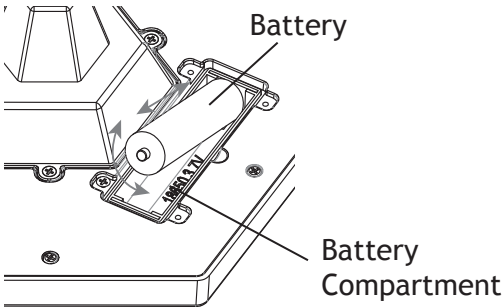

Insert the battery into the battery compartment.

3 Reinstall Battery Compartment Cover

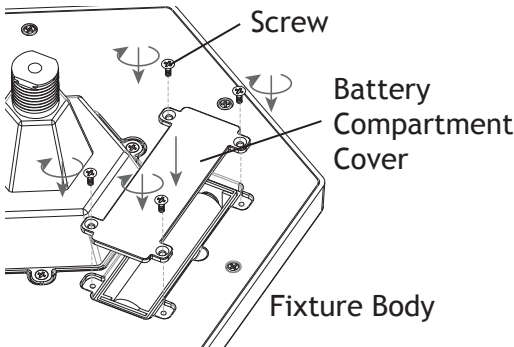

Place the battery compartment cover back onto the fixture body and secure with the previously removed screws.

4 Test Solar Light

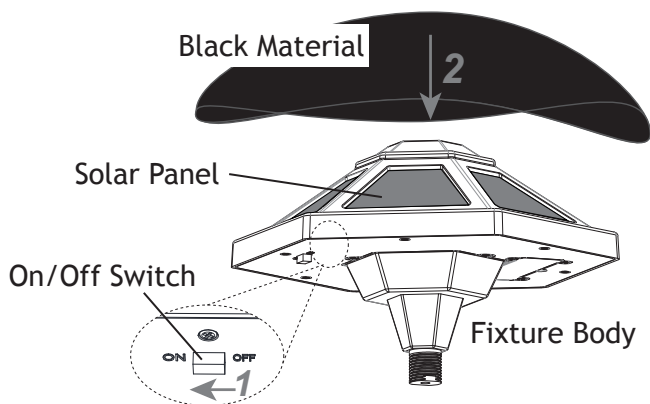

Slide the ON/OFF switch of the fixture to the “ON” position. Cover solar panels completely by using black materials. The fixture will light up when the solar panel is covered and turn back off when it is uncovered.

Now you can proceed to next steps of installations knowing the fixture is in ON mode.

5 Install Riser

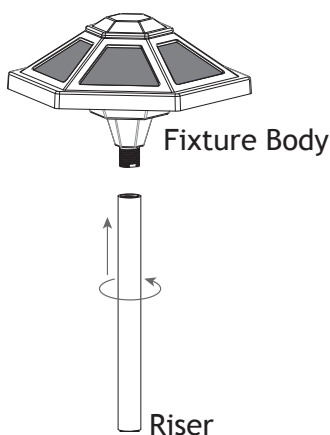

Thread the riser onto the fixture and hand tighten until snug.



6 Install Stake

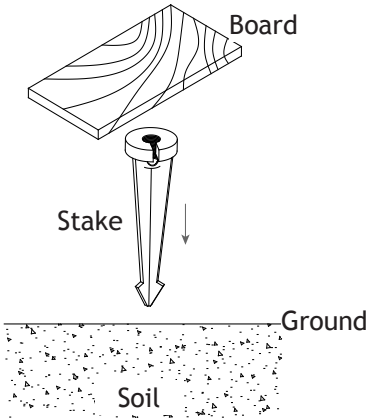

Determine the desired location for mounting the stake mount. Hammer the stake into the ground until flange of stake is flush to grade. To avoid damage to the stake, place a board on top of the stake while hammering.

Note: If the ground is hard and the stake is difficult to install, make a crosscut in the ground using a flat shovel.

7 Install Stake

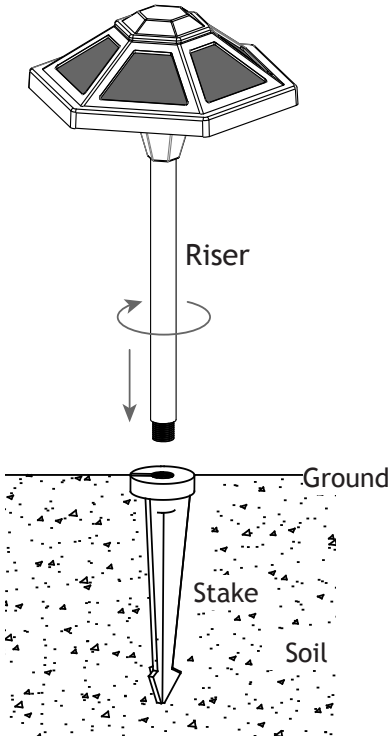

Thread the riser on to the stake and hand tighten until snug.



Help Hotline:

1-813-978-3700 • Mon-Fri 8am-8pm • Sat-Sun 10am - 6pm (EST)

www.voltlighting.com

Specifications and product details subject to change without notice.
© Copyright 2023, VOLT® Lighting, Lutz FL USA 33549 • All rights reserved.
customersupport@voltlighting.com • 813.978.3700