



AMP® 12V LED Lamps

Amber Turtle Safe LED MR11 and MR16 Series

Product Description

AMP® Amber LED bulbs are designed to match the form factor and illumination of the incandescent bulbs they replace. We have created these to counteract the effects of light pollution near beaches causing turtles to come inland where oftentimes they perish. Instead; with turtle safe lights, the turtles will safely return to the ocean where they belong.

These lamps are instant-on. They are within the required nanometer range of 590-605 to protect the sea turtles for which they are designed. This wavelength of light provides adequate lighting for humans while remaining virtually invisible to the turtles. Each lamp has an estimated life of 40,000 Hrs.

Lifetime Replacement Warranty (for residential applications); the warranty for commercial projects is 10 years.



Product Dimensions

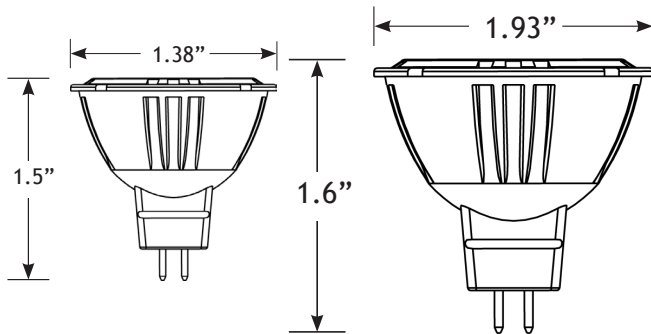

*MR11 pictured here

*MR16 pictured here

Specifications

- ▶ **Input Voltage, Frequency:** 6-18VAC, 50/60Hz, with decreased lumens under 10V
- ▶ **Beam Angles:** 60° (wide flood)
- ▶ **Color:** Amber
- ▶ **Life:** 40,000 hours (L70)
- ▶ **Nanometer Range:** 590-605

Warranty

Residential: Lifetime Warranty
Commercial: 10-Year Warranty

Requirements

MUST BE INSTALLED IN A LOW MOUNTED, DOWNWARD DIRECTED AND SHIELDED FIXTURE.

Features & Benefits

- ▶ Replacements for:
 - 15W Halogen MR11s and MR16s
 - 60° Beam Angles
- ▶ Reduces energy consumption by about 75%
- ▶ Lasts up to 8 times longer than halogen lamps
- ▶ No warm-up time, instant-on with full light output and stable lamp to lamp color
- ▶ Suitable for use in enclosed fixtures

Specifications subject to change without notice.