

## **INSTALLATION & MAINTENANCE GUIDE**

### **AMP® LOW VOLTAGE LANDSCAPE LIGHTING**

AMP® Nano LED Spotlight

**ITEM: AAL-1049**

1-813-978-3900 • Mon-Fri 9am-6pm (EST)

**! IMPORTANT SAFETY INSTRUCTIONS: READ BEFORE INSTALLATION**

This luminaire is intended for installation in accordance with local codes and the National Electric Code (NEC). Failure to adhere to these codes and instructions may result in serious injury, property damage and void the warranty.

These instructions do not intend to cover all variations in installation, operation maintenance or mounting situations.

1. Make sure the power is turned OFF before installing or servicing this luminaire.
2. **WARNING:** risk of electrical shock. Install all luminaires 10 feet (3.05M) or more from pool, spa or fountain.
3. This luminaire is intended to be used only with a power supply (transformer) rated maximum of 300 watts (25 AMPS) at 15 volts.
4. Wiring connections must be made with UL listed wire connectors that are suitable for outdoor use.
5. Position the low voltage wire and wire connector so that it is located within 6 inches (15.2 cm) from a building structure, a luminaire or fitting.
6. The main low voltage cable is intended for shallow burial - less than 6 inches (152 mm).

**! IMPORTANT SAFETY INSTRUCTIONS****INSTRUCTIONS PERTAINING TO A RISK OF FIRE, OR INJURY TO PERSONS**  
**LIGHTED LAMP IS HOT!**

**WARNING** – To reduce the risk of FIRE OR INJURY TO PERSONS.

1. Turn off/unplug and allow to cool before replacing lamp.
2. Lamp gets HOT quickly! Contact only switch/plug when turning on.
3. Do not touch the hot lens, guard or enclosure.
4. Keep lamp away from materials that may burn.
5. Do not touch lamp at any time. Use a soft cloth. Oil from skin may damage lamp.
6. Do not operate the luminaire fitting with a missing or damaged shield.

**SAVE THESE INSTRUCTIONS**

## PACKAGE CONTENTS

- A. (1) Fixture Body
- B. (1) Allen Wrench
- C. (1) Stake

## PRODUCT DIMENSIONS

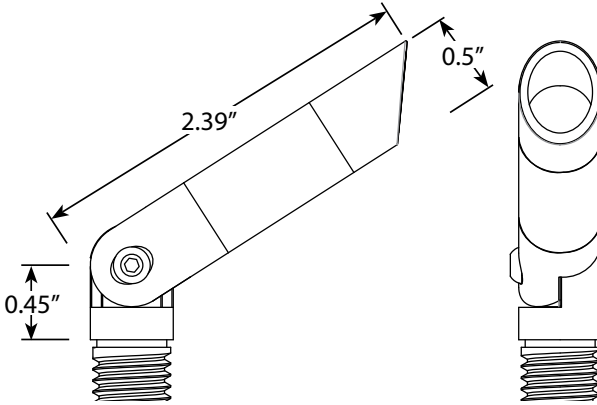

## 1 INSTALL FIXTURE BODY TO STAKE

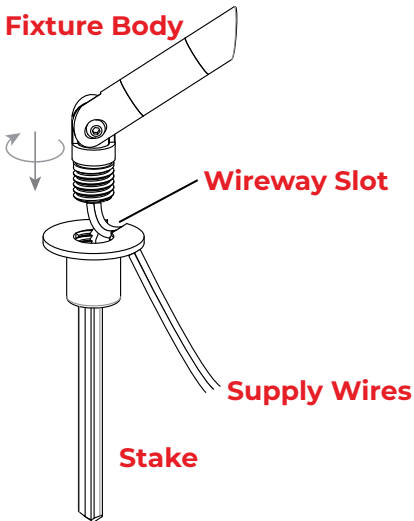

Pass the supply wire of the fixture body through the wireway slot on the stake. Thread the fixture body onto the stake.

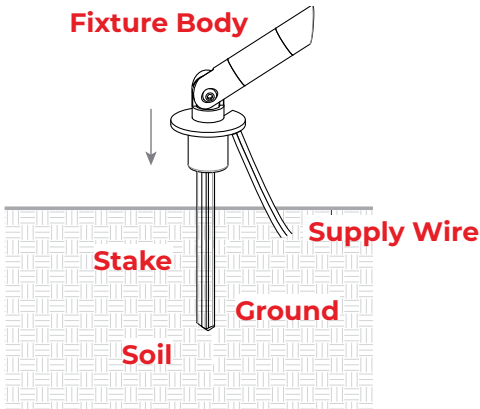
**2 INSTALL STAKE INTO SOIL**

Insert the stake into the soil until flange of stake is flush to the ground.

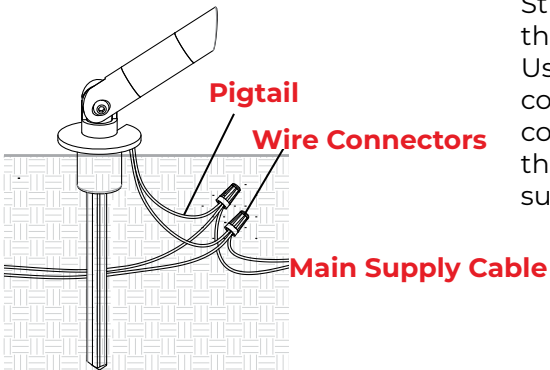
**3 WIRE CONNECTIONS**

Strip both the leads from the luminaire pigtail. Using two UL listed wire connectors (sold separately), connect the leads from the luminaire to the main supply cable leads.

## 4 ADJUST DIRECTIONS

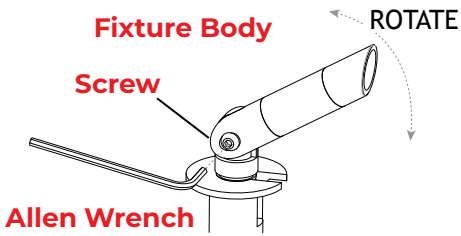

By using the Allen wrench, loosen the screw at the joint and adjust the luminaire to the desired direction. Once the desired direction is achieved, tighten the screw.



# INSTALLATION & MAINTENANCE GUIDE

AMP® Nano LED Spotlight - AAL-1049





1-813-978-3900 · Mon-Fri 9am-6pm (EST)

Specifications and product details subject to change without notice.  
© Copyright 2023, AMP® Lighting, Lutz FL USA 33549 · All rights reserved.  
[customersupport@amplighting.com](mailto:customersupport@amplighting.com) · [amplighting.com](http://amplighting.com)