

AMP®

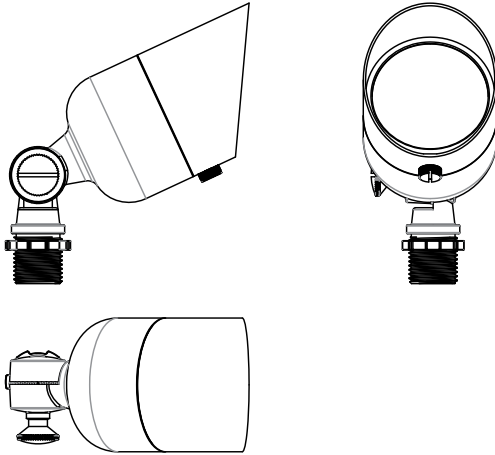

INSTALLATION & MAINTENANCE GUIDE

AMP® LOW VOLTAGE LANDSCAPE LIGHTING

AMP® G2 EcoPro

ITEM: AAL-1052

1-813-978-3900 • Mon-Fri 9am-6pm (EST)

! IMPORTANT SAFETY INSTRUCTIONS: READ BEFORE INSTALLATION

This luminaire is intended for installation in accordance with local codes and the National Electric Code (NEC). Failure to adhere to these codes and instructions may result in serious injury, property damage and void the warranty.

These instructions do not intend to cover all variations in installation, operation maintenance or mounting situations.

1. Make sure that the power is turned OFF before installing or servicing this luminaire.
2. **WARNING:** risk of electrical shock. Install all luminaires 10 feet (3.05M) or more from pool, spa or fountain.
3. This luminaire is intended to be used only with a power supply (transformer) rated maximum of 300 watts (25 AMPS) at 15 volts.
4. Wiring connections must be made with UL listed wire connectors that are suitable for outdoor use.
5. Position the low voltage wire and wire connector so that it is located within 6 inches (15.2 cm) from a building structure, a luminaire or fitting.
6. The main low voltage cable is intended for shallow burial - less than 6 inches (152 mm).

! IMPORTANT SAFETY INSTRUCTIONS**INSTRUCTIONS PERTAINING TO A RISK OF FIRE, OR INJURY TO PERSONS**
LIGHTED LAMP IS HOT!

WARNING – To reduce the risk of FIRE OR INJURY TO PERSONS.

1. Turn off/unplug and allow to cool before replacing lamp.
2. Lamp gets HOT quickly! Contact only switch/plug when turning on.
3. Do not touch the hot lens, guard or enclosure.
4. Keep lamp away from materials that may burn.
5. Do not touch lamp at any time. Use a soft cloth. Oil from skin may damage lamp.
6. Do not operate the luminaire fitting with a missing or damaged shield.

SAVE THESE INSTRUCTIONS

PACKAGE CONTENTS

A. (1) Fixture Body

PRODUCT DIMENSIONS

A. (1) MR16 Lamp

B. Mounting Accessory

PRODUCT DIMENSIONS

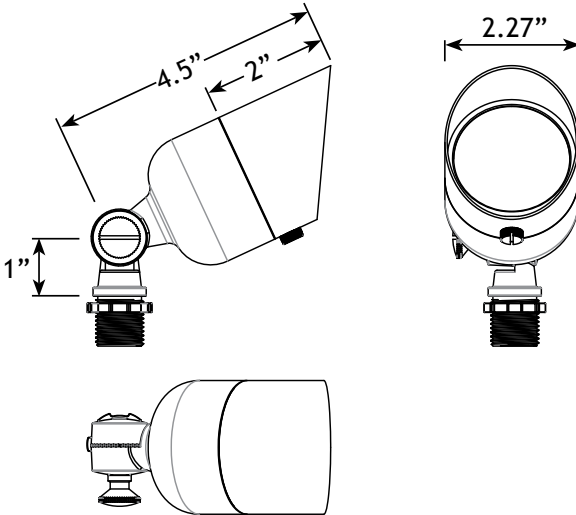

1

REMOVE GLARE GUARD

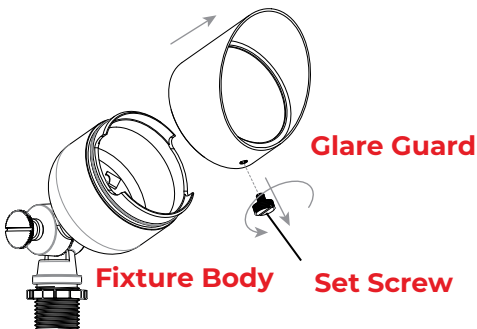

Loosen the set screw and remove the glare guard from the fixture body.

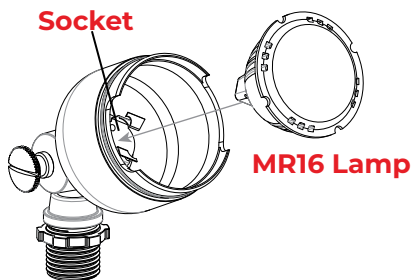
2 INSTALL MR11 LAMP

Insert MR16 lamp with correct wattage and type marked on fixture label.

CAUTION: Do not exceed maximum wattage marked on luminaire label.

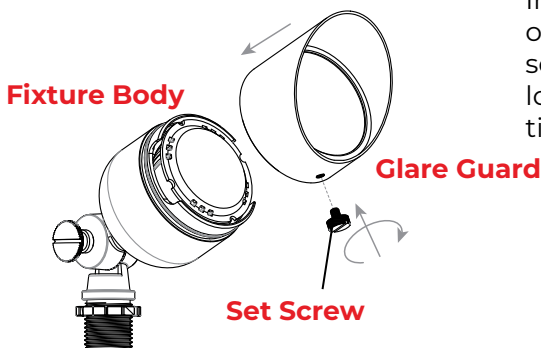
3 INSTALL GLARE GUARD

Install the glare guard back onto the fixture body and secure with previously loosened set screw. Hand tighten until snug.

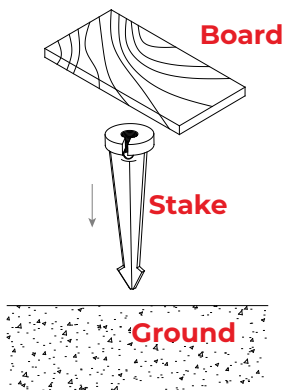
4 INSTALL STAKE

Determine the desired location for mounting the fixture. Hammer the stake into the ground until flange of stake is flush to grade. To avoid damage to the stake, place a board on top of the stake while hammering.

NOTE: If the ground is hard and the stake is difficult to install, make a crosscut in the ground using a flat shovel.

5 INSTALL FIXTURE BODY TO STAKE

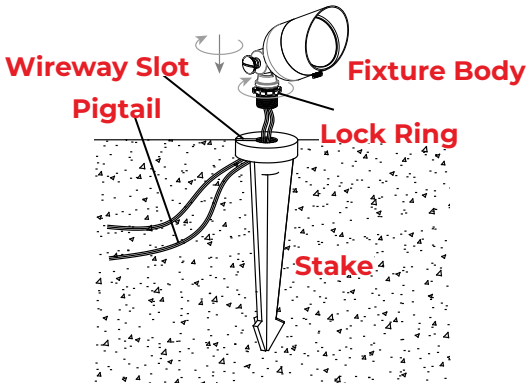

Clear away an area in the ground at the wireway slot on top of the stake. Lay the luminaire pigtail into the wireway slot and screw the fixture body on to the stake. Tighten the lock ring against the stake and hand tighten until snug.

5 WIRE CONNECTION

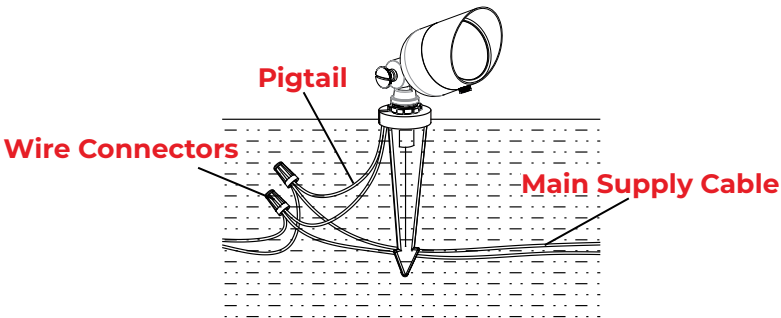

Strip both the leads from the luminaire pigtail. Using two UL listed wire connectors (sold separately), connect the leads from the luminaire to the main supply cable leads.

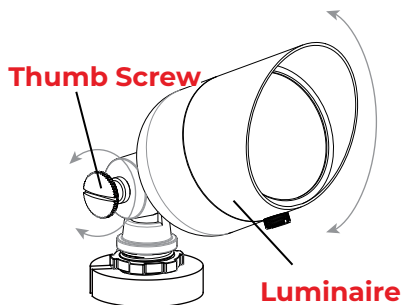
6 ADJUST LUMINAIRE DIRECTIONS

Loosen the knuckle screw at the joint. Rotate the luminaire to your desired direction. Tighten the knuckle screw once your desired direction is achieved.

INSTALL/REPLACE LAMP

Please reverse Step 2 - Step 3 to expose the MR16 lamp and replace it with the correct wattage and type marked on the fixture label. Then, reinstall the glare guard.

IMPORTANT: The MR16 lamp must be protected from moisture and dust at all times. Always reinstall the glare guard when moved.



1-813-978-3900 · Mon-Fri 9am-6pm (EST)

Specifications and product details subject to change without notice.
© Copyright 2023, AMP® Lighting, Lutz FL USA 33549 · All rights reserved.
customersupport@amplighting.com · amplighting.com