

INSTALLATION & MAINTENANCE GUIDE

AMP® LOW VOLTAGE LANDSCAPE LIGHTING

AMP® Mini PinnaclePro Black Path & Area Light

ITEM: APL-3017-4-B-BK

1-813-978-3900 • Mon-Fri 9am-6pm (EST)

! IMPORTANT SAFETY INSTRUCTIONS: READ BEFORE INSTALLATION

This luminaire is intended for installation in accordance with local codes and the National Electric Code (NEC). Failure to adhere to these codes and instructions may result in serious injury, property damage and void the warranty.

These instructions do not intend to cover all variations in installation, operation maintenance or mounting situations.

1. Make sure the power is turned OFF before installing or servicing this luminaire.
2. **WARNING:** risk of electrical shock. Install all luminaires 10 feet (3.05M) or more from pool, spa or fountain.
3. This luminaire is intended to be used only with a power supply (transformer) rated maximum of 300 watts (25 AMPS) at 15 volts.
4. Wiring connections must be made with wire connectors that are suitable for outdoor use.
5. Position the low voltage wire and wire connector so that it is located within 6 inches (15.2 cm) from a building structure, a luminaire or fitting.
6. The main low voltage cable is intended for shallow burial - less than 6 inches (152 mm).
7. If additional lengths of low voltage cable are required, please contact www.amplighting.com or call 1-813-978-3900.

! IMPORTANT SAFETY INSTRUCTIONS**INSTRUCTIONS PERTAINING TO A RISK OF FIRE, OR INJURY TO PERSONS**
LIGHTED LAMP IS HOT!

WARNING – To reduce the risk of FIRE OR INJURY TO PERSONS.

1. Turn off/unplug and allow to cool before replacing lamp.
2. Lamp gets HOT quickly! Contact only switch/plug when turning on.
3. Do not touch the hot lens, guard or enclosure.
4. Keep lamp away from materials that may burn.
5. Do not touch lamp at any time. Use a soft cloth. Oil from skin may damage lamp.
6. Do not operate the luminaire fitting with a missing or damaged shield.

SAVE THESE INSTRUCTIONS

PACKAGE CONTENTS

- A. (1) Stem
- B. (1) Fixture Body

- C. (1) Stake

PRODUCT DIMENSIONS

- A. (1) MR11 Bulb

PRODUCT DIMENSIONS

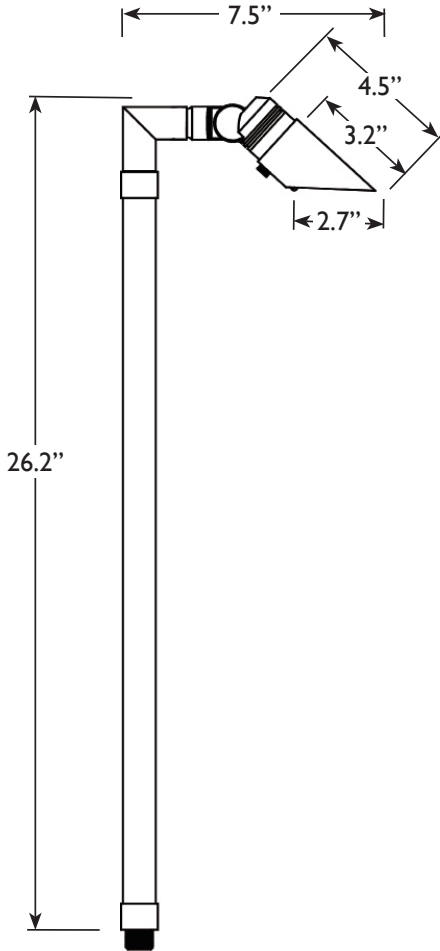

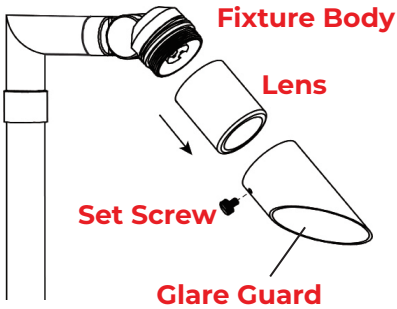
1 REMOVE LENS AND GLARE GUARD

Loosen the set screw and remove the glare guard from the lens. Remove the lens from the fixture body.

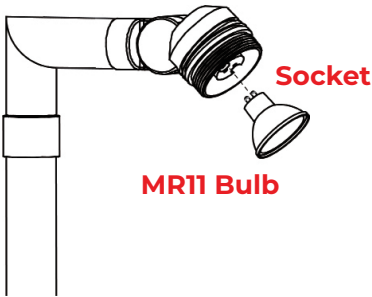
2 INSTALL BULB

Insert the bulb with the correct wattage and type marked on the fixture label.

CAUTION: Do not exceed maximum wattage marked on luminaire label.

NOTE: DO NOT touch bulb with bare hands. Use soft cloth to handle bulb.

3 INSTALL LENS AND GLARE GUARD

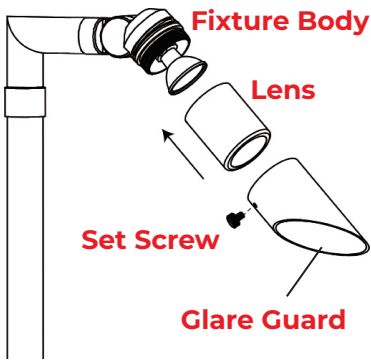

Place the shield over the bulb and thread onto the fixture. Attach the glare guard back onto the shield and secure with the set screw.

4 INSTALL STAKE

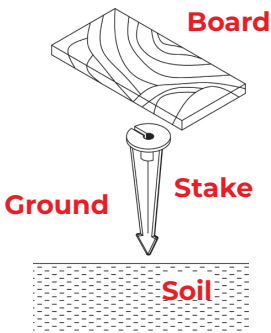

Determine the desired location for mounting the fixture. Hammer the stake into the ground until flange of stake is flush to grade. To avoid damage to the stake, place a board on top of the stake while hammering.

NOTE: If the ground is hard and the stake is difficult to install, make a crosscut in the ground using a flat shovel.

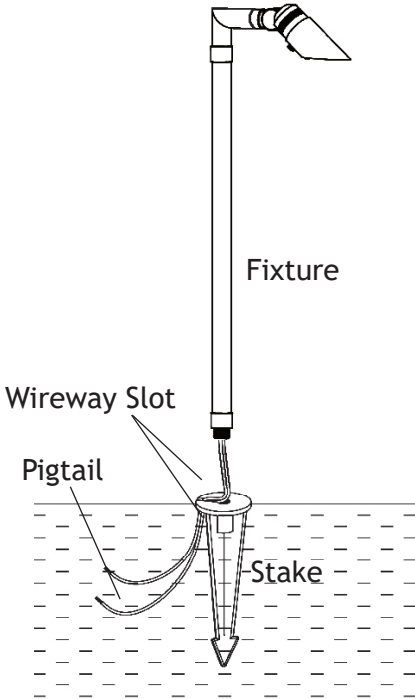
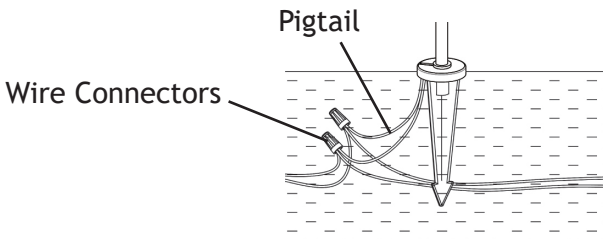
5 INSTALL FIXTURE**6 WIRE CONNECTION**

7 ADJUST ANGLE OF FIXTURE

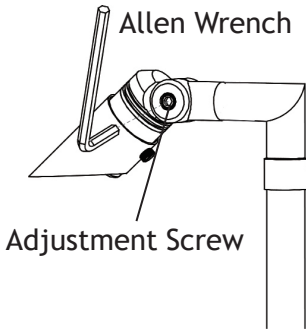

Using an Allen Wrench, loosen the adjustment screws and modify the fixture body to the desired angle. Then tighten the adjustment screws.

INSTALL/REPLACE LAMP

Remove the glare guard and the lens to expose the MR11 lamp and replace it with the correct wattage and type marked on the fixture label. Then, reinstall the lens and the glare guard.

IMPORTANT: MR11 lamp must be protected from moisture and dust at all times. Always reinstall the lens and the glare guard when removed.



1-813-978-3900 · Mon-Fri 9am-6pm (EST)

Specifications and product details subject to change without notice.
© Copyright 2023, AMP® Lighting, Lutz FL USA 33549 · All rights reserved.
customersupport@amplighting.com · amplighting.com