

INSTALLATION & MAINTENANCE GUIDE

AMP® LOW VOLTAGE LANDSCAPE LIGHTING

AMP® MarinerPro Brass RGBW LED Underwater Light

ITEM: AUL-8009

1-813-978-3900 • Mon-Fri 9am-6pm (EST)

! IMPORTANT SAFETY INSTRUCTIONS: READ BEFORE INSTALLATION

This luminaire is intended for installation in accordance with local codes and the National Electric Code (NEC). Failure to adhere to these codes and instructions may result in serious injury, property damage and void the warranty.

These instructions do not intend to cover all variations in installation, operation maintenance or mounting situations.

1. Use only in ponds and small decorative fountains where persons will immerse no more than their hands and lower arms while the product is energized.
2. **DO NOT** use in water intended for swimming, wading, immersion, or bathing.
3. All installer completed cable connections must be located outside of pond or fountain.
4. Low voltage circuit must be supplied by a power unit marked as suitable for supplying submersible luminaires.
5. Power unit must be supplied by a circuit protected by a ground fault circuit interrupter (GFCI).
6. "Maximum depth: 18 in (450 mm)".

! IMPORTANT SAFETY INSTRUCTIONS**INSTRUCTIONS PERTAINING TO A RISK OF FIRE, OR INJURY TO PERSONS**
LIGHTED LAMP IS HOT!

WARNING – To reduce the risk of FIRE OR INJURY TO PERSONS.

1. Turn off/unplug and allow to cool before replacing lamp.
2. Lamp gets HOT quickly! Contact only switch/plug when turning on.
3. Do not touch the hot lens, guard or enclosure.
4. Keep lamp away from materials that may burn.
5. Do not touch lamp at any time. Use a soft cloth. Oil from skin may damage lamp.
6. Do not operate the luminaire fitting with a missing or damaged shield.

SAVE THESE INSTRUCTIONS

PACKAGE CONTENTS

A. (1) Fixture Body

PRODUCT DIMENSIONS

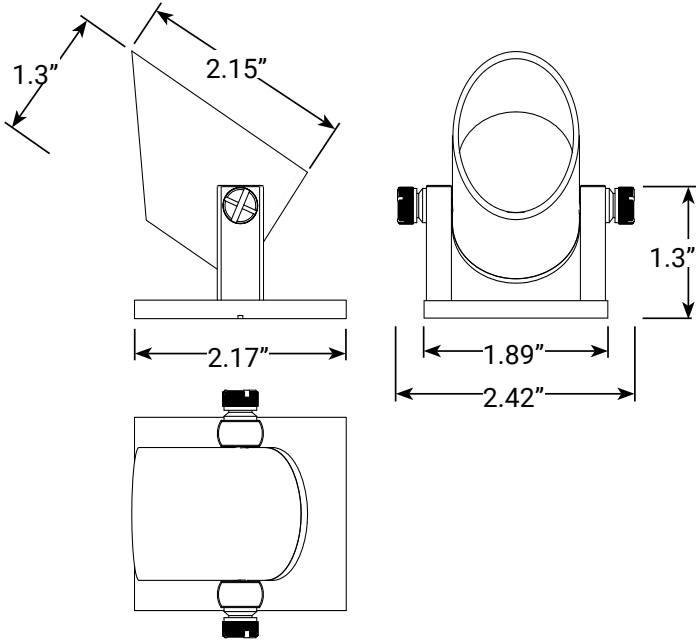

1 WIRE CONNECTIONS

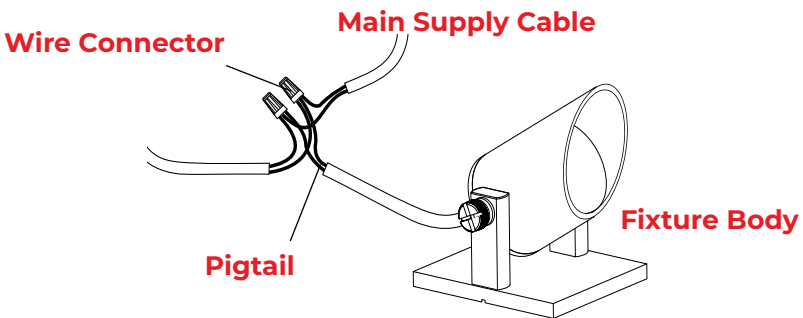

Place fixture body on your desired location. Strip both leads from luminaire pigtail. Using two UL listed wire connectors (sold separately), connect the leads from the luminaire to main supply cable leads. Make this connection at least 10 feet outside of the water.

RGBW IR REMOTE CONTROLLER INSTRUCTIONS

RGBW IR Remote Controller is suitable for this fixture. Refer to the following instructions for the remote controller. If the fixture is placed in deep water, it will need to be removed in order for the remote to work properly.

Two AAA batteries are required for the IR Remote.

1 REMOVE THE BATTERY COMPARTMENT COVER

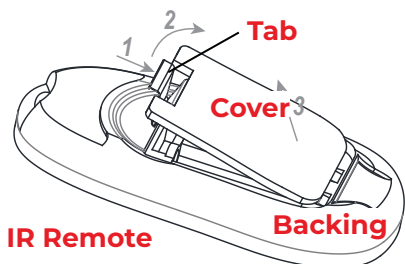

Press the tab and rotate the battery compartment cover to remove it from the IR Remote.

2 INSTALL TWO AAA BATTERIES

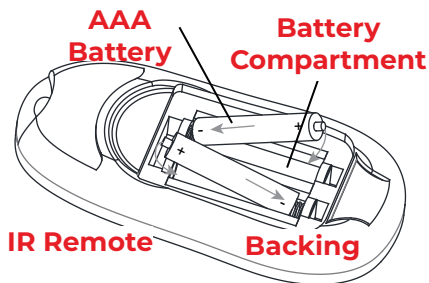

Place two AAA batteries into the battery compartment properly.

3 INSTALL THE BATTERY COMPARTMENT COVER

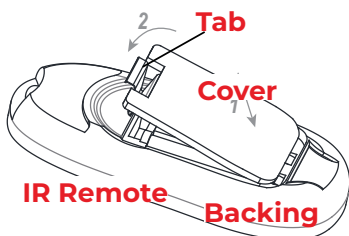

Place the battery compartment cover back onto the IR Remote.

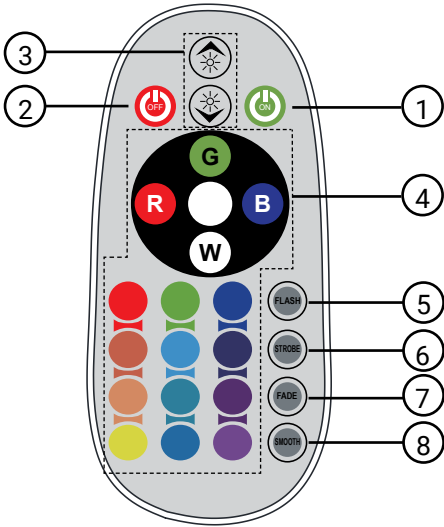

1. On
2. Off
3. Brightness Control
4. 16 color selections
5. Flash
 - a. Mode 1: Repeats Red, Green, Blue + color cycle for 1 second duration of each of the seven colors within this mode.
 - a. Mode 2: Hit flash a second time and this mode slowly blends the same seven colors from mode one, mixing them together.

2. Strobe

- a. Mode 1: Pick any color on the remote, then press strobe and that color will strobe every second alternating between on and off.
- a. Mode 2: Hit strobe a second time and this mode will strobe a blended white color at the same speed as before.

2. Fade

- a. Mode 1: Pick any color on the remote, then press fade and that color will slowly fade in and out every second.
- a. Mode 2: Hit fade a second time and it will fade a blended white color in and out at the same speed as before.

2. Smooth

- a. Mode 1: Repeats a flash cycle of Red, Green, and Blue only.
- a. Mode 2: Hit smooth a second time and this mode slowly blends Red, Green, and Blue only; in and out of each other at the same speed.



1-813-978-3900 · Mon-Fri 9am-6pm (EST)

Specifications and product details subject to change without notice.
© Copyright 2023, AMP® Lighting, Lutz FL USA 33549 · All rights reserved.
customersupport@amplighting.com · amplighting.com