

INSTALLATION & MAINTENANCE GUIDE

AMP® LOW VOLTAGE LANDSCAPE LIGHTING

AMP® Par36 Well Light

ITEM: AWL-5000-4-P-BK

1-813-978-3900 • Mon-Fri 9am-6pm (EST)

! IMPORTANT SAFETY INSTRUCTIONS: READ BEFORE INSTALLATION

This luminaire is intended for installation in accordance with local codes and the National Electric Code (NEC). Failure to adhere to these codes and instructions may result in serious injury, property damage and void the warranty.

These instructions do not intend to cover all variations in installation, operation maintenance or mounting situations.

1. Make sure the power is turned OFF before installing or servicing this luminaire.
2. **WARNING:** risk of electrical shock. Install all luminaires 10 feet (3.05M) or more from pool, spa or fountain.
3. This luminaire is intended to be used only with a power supply (transformer) rated maximum of 300 watts (25 AMPS) at 15 volts.
4. Wiring connections must be made with UL listed wire connectors that are suitable for outdoor use.
5. Position the low voltage wire and wire connector so that it is located within 6 inches (15.2 cm) from a building structure, a luminaire or fitting.
6. The main low voltage cable is intended for shallow burial - less than 6 inches (152 mm).

! IMPORTANT SAFETY INSTRUCTIONS**INSTRUCTIONS PERTAINING TO A RISK OF FIRE, OR INJURY TO PERSONS**
LIGHTED LAMP IS HOT!

WARNING – To reduce the risk of FIRE OR INJURY TO PERSONS.

1. Turn off/unplug and allow to cool before replacing lamp.
2. Lamp gets HOT quickly! Contact only switch/plug when turning on.
3. Do not touch the hot lens, guard or enclosure.
4. Keep lamp away from materials that may burn.
5. Do not touch lamp at any time. Use a soft cloth. Oil from skin may damage lamp.
6. Do not operate the luminaire fitting with a missing or damaged shield.

SAVE THESE INSTRUCTIONS

PACKAGE CONTENTS

- A. (1) Tube
- B. (1) Lamp Holder
- C. (1) "U" bracket
- A. (2) Screws
- B. (2) Nuts

PARTS REQUIRED

- A. (1) PAR36 Lamp (sold separately)
- A. (1) Debris Cover (glass + louvers) (sold separately, optional)

PRODUCT DIMENSIONS

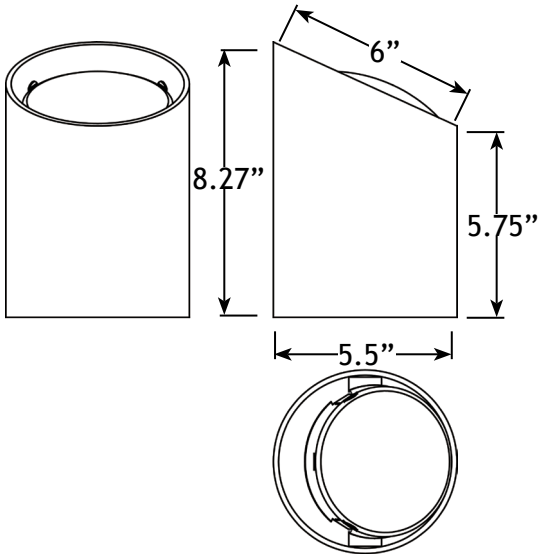

1 INSTALL TUBE

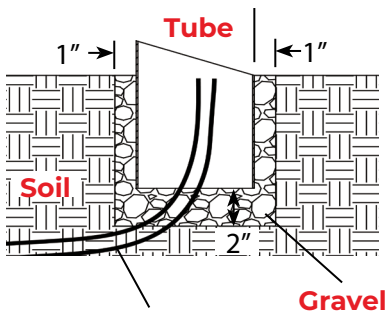

**Main Low Voltage
Supply Wire**

Gravel

Dig a 6.5" diameter, 8" deep hole in the ground. Run the main low voltage supply wires to the hole.

Place 2" of gravel in the bottom of the hole for proper drainage. Place the tube inside of the hole and add the additional gravel around the tube sides.

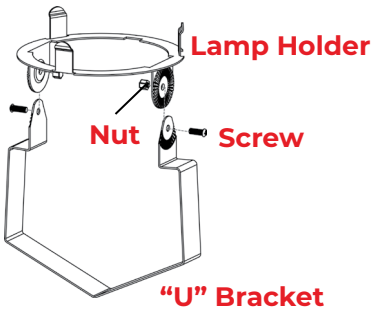
2 **INSTALL LAMP HOLDER**

Attach the lamp holder onto the “U” bracket by lining up the holes, then pass the screws through the holes and secure with the provided nuts.

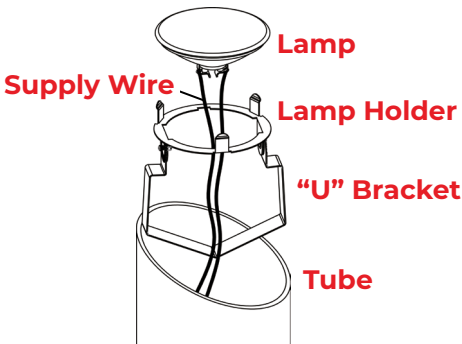
3 **INSTALL LAMP**

Use the PAR36 lamp with the correct wattage and type marked on the fixture label.

Pass the supply wires through the center of the lamp holder. Connect the supply wires to the bottom of the lamp. Snap the lamp onto the lamp holder and then push the “U” bracket with the lamp into the tube.

CAUTION: Do not exceed maximum wattage marked on luminaire label.

NOTE: DO NOT touch lamp with bare hands. Use soft cloth to handle lamp.

4 INSTALL DEBRIS COVER (OPTIONAL)

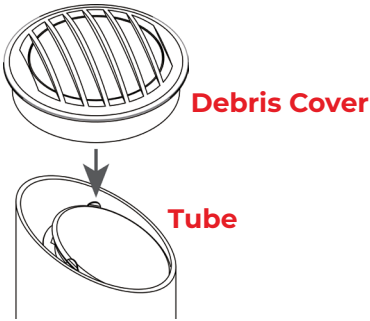

Attach the debris cover onto the top end of the tube if necessary.

NOTE: Debris cover is not for use with 50 watt halogen lamps.

5 WIRE CONNECTION

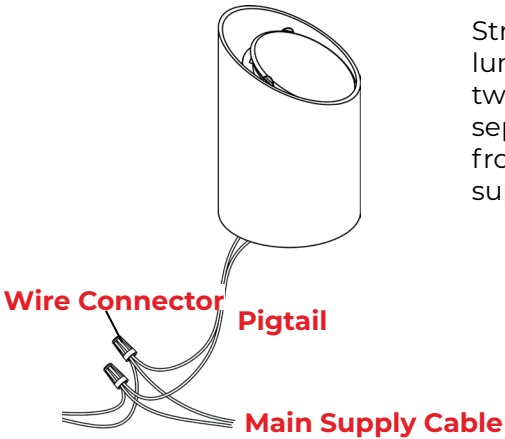

Strip both leads from the luminaire pigtail. Using two wire connectors (sold separately), connect the leads from the luminaire to the main supply cable leads.



INSTALLATION & MAINTENANCE GUIDE

AMP® Par36 Well Light - AWL-500-4-P-BK



1-813-978-3900 · Mon-Fri 9am-6pm (EST)

Specifications and product details subject to change without notice.
© Copyright 2023, AMP® Lighting, Lutz FL USA 33549 · All rights reserved.
customersupport@amplighting.com · amplighting.com