

## **INSTALLATION & MAINTENANCE GUIDE**

### **AMP® LOW VOLTAGE LANDSCAPE LIGHTING**

AMP® HydraPro™ Black In-Grade Light (Lamp-Ready)

**ITEM: AWL-5006**

**! IMPORTANT SAFETY INSTRUCTIONS: READ BEFORE INSTALLATION**

This fixture is intended for installation in accordance with local codes and the National Electric Code (NEC). Failure to adhere to these codes and instructions may result in serious injury, property damage and void the warranty.

These instructions do not intend to cover all variations in installation, operation maintenance or mounting situations.

1. Make sure that the power is turned OFF before installing or servicing this fixture.
2. Warning: this fixture is not intended to be installed within 10 feet [3 meters] of a pool, spa or fountain.
3. This fixture is intended to be used only with a power supply (transformer) rated maximum of 300 watts (25 AMPS) at 15 volts.
4. Underground Low Energy Cable must not be buried over 6" (15.2 cm) in order to connect to the main low voltage cable.
5. Wiring connections must be made with UL listed wire connectors that are suitable for the application.
6. Position the wire connector so that it is located within 6 inches (15.2 cm) from a building structure, a luminaire, or fitting.

**! IMPORTANT SAFETY INSTRUCTIONS****INSTRUCTIONS PERTAINING TO A RISK OF FIRE, OR INJURY TO PERSONS**  
**LIGHTED LAMP IS HOT!**

**WARNING** – To reduce the risk of FIRE OR INJURY TO PERSONS.

1. Turn off/unplug and allow to cool before replacing lamp.
2. Lamp gets HOT quickly! Contact only switch/plug when turning on.
3. Do not touch the hot lens, guard or enclosure.
4. Keep lamp away from materials that may burn.
5. Do not touch lamp at any time. Use a soft cloth. Oil from skin may damage lamp.
6. Do not operate the luminaire fitting with a missing or damaged shield.

**SAVE THESE INSTRUCTIONS**

## PACKAGE CONTENTS

A. (1) Fixture Body

## PARTS REQUIRED (SOLD SEPARATELY)

A. (1) MR11 Lamp

## PRODUCT DIMENSIONS

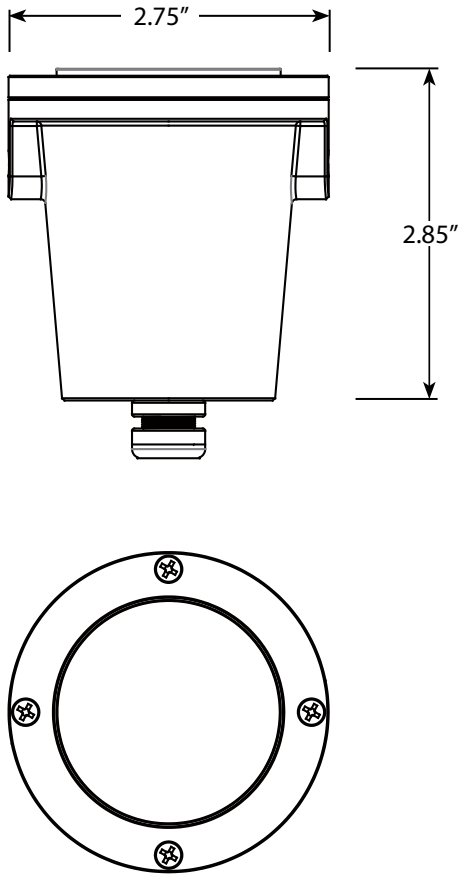

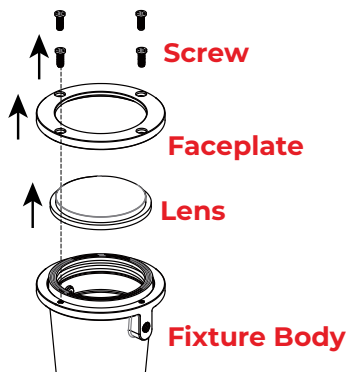
**1 REMOVE FACEPLATE**

Use a screwdriver to loosen the screws on the faceplate and remove the lens from the fixture body.

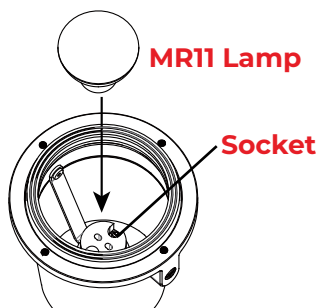
**2 INSTALL LAMP**

Insert the lamp with the correct wattage and type marked on the fixture label and push firmly into place.

**CAUTION:** Do not exceed maximum wattage marked on fixture label.

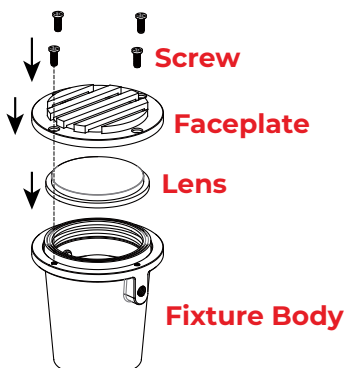
**3 INSTALL FACEPLATE**

Place the lens and the faceplate back onto the fixture body and secure the removed screws in a star pattern using a screwdriver. Tighten until snug.

## 4 REMOVE THE LENS

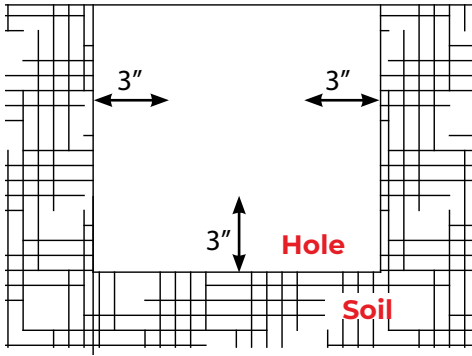

Prepare a hole in the ground. Make sure there are approximately 3" spaces surrounding the fixture for pea gravel or sand.

## 5 WIRE CONNECTION

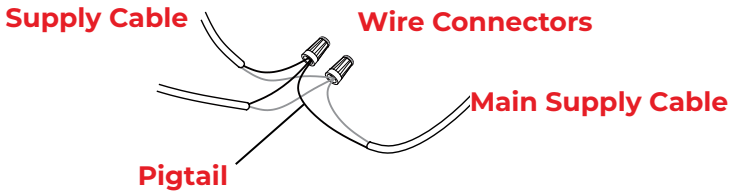

Strip both leads from the luminaire pigtail. Using two wire connectors (sold separately), connect the leads from the fixture body to the main supply cable leads.

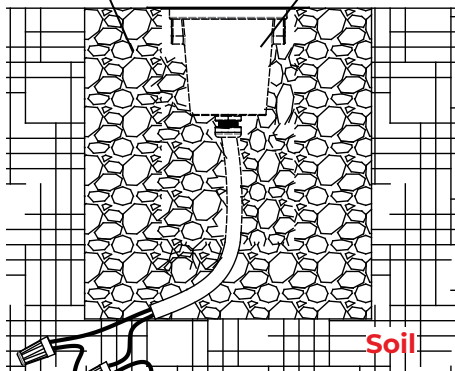
**6 FILL HOLE****Pea Gravel or Sand** **Fixture**

Install the fixture in the hole and fill the hole with pea gravel or sand.

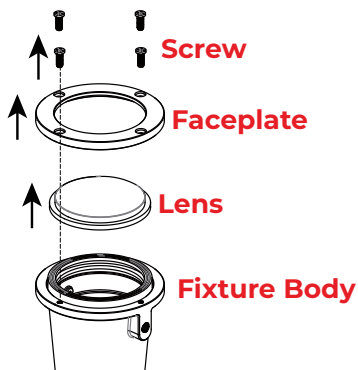
**INSTALL/REPLACE GLARE GUARD****7 REMOVE FACEPLATE**

Use a screwdriver to loosen the screws on the faceplate and remove the lens from the fixture body.

## 8 REPLACE FACEPLATE

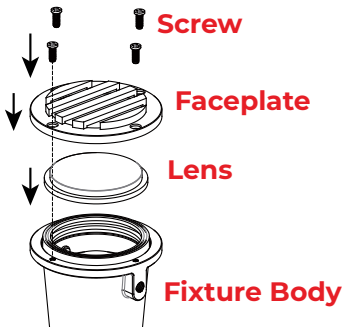

Place the lens and faceplate onto the fixture body and secure with previously removed screws in a star pattern. Hand tighten until snug with a screwdriver.

### Faceplate Replacement Options

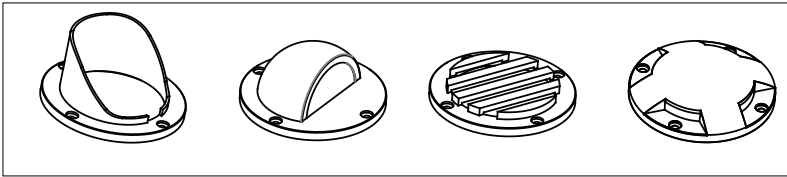

## INSTALL/REPLACE LAMP

Repeat step 1 - step 3 to remove the faceplate and expose the lamp. Replace it with the correct wattage and type marked on the fixture label. Then, reinstall the faceplate.

**IMPORTANT:** Lamps must be protected from moisture and dust at all times. Always reinstall the faceplate when removed.



1-813-978-3900 · Mon-Fri 9am-6pm (EST)

Specifications and product details subject to change without notice.  
© Copyright 2023, AMP® Lighting, Lutz FL USA 33549 · All rights reserved.  
[customersupport@amplighting.com](mailto:customersupport@amplighting.com) · [amplighting.com](http://amplighting.com)