



# AMP® Low Voltage Landscape Lighting Pro 900 & 1200 Watt 12-22V Multi-Tap Transformer

## Product Description

AMP® 12-22V Landscape Lighting Transformers feature top-of-the-line internal and external components for professional results and commercial reliability. The extra large voltage taps make these truly the perfect solution for large landscape lighting systems - especially those with very long (or heavily loaded) wire runs. The extremely reliable, efficient, and quiet toroidal magnetic core lasts a lifetime. The transformer also runs cooler than conventional laminated magnetic types. The solid stainless steel body further ensures that this transformer will never corrode. The 12-22 volt taps provide the ability to compensate for voltage loss. For example, using the 22 volt tap, you could install up to 60W of LED lights with a wire run of 600 ft. of #10/2 cable! (Note - we don't advise planning for such long runs - better to relocate your transformer). The 22 volt tap also allows you to increase your transformer load on shorter runs. For example, with a 150 ft. run using #10/2 - you can load up to 140W of LED lights. Easily one of the best low voltage transformers on the market. Don't settle on any lesser quality! Order your commercial-grade low voltage transformer today from AMP®

## Product Dimensions

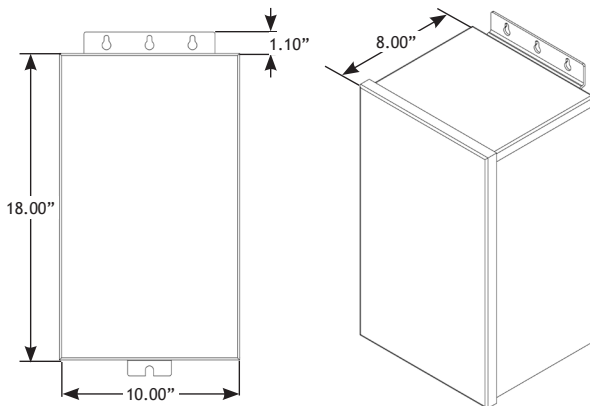

## Specifications

- ▶ **Housing:** Non-brushed 304 stainless steel with removable cover
- ▶ **Power Cord:** 60" black 18AWG SJTW cord and plug set
- ▶ **Input Voltage:** 120V
- ▶ **Voltage Taps:**
  - 12-22V
- ▶ **Primary Circuit Protection:** Automatic (auto reset) thermal breaker in core
- ▶ **Secondary Circuit Protection:**
  - (3) 25A magnetic circuit breakers (900w)
  - (4) 25A magnetic circuit breakers (1200w)

## Features & Benefits

- ▶ Highly efficient toroidal core\* - runs cooler, generates less noise, with less voltage loss under load.
- ▶ Unique color-coded wire markers for easy maintenance and troubleshooting.
- ▶ Extra-large voltage taps (UL 1838 compliant) - to accommodate landscape lighting systems of any size.
- ▶ Available in 900w and 1200w capacities
- ▶ Includes a photocell and timer receptacle.
- ▶ ETL Listed for both indoor and outdoor use.

## Certifications



## Warranty

Lifetime Warranty