

PRODUCT SPECIFICATIONS

AMP[®]

Project Name _____ Date _____

Type or Model _____ Qty _____

AMP[®] Low Voltage Landscape Lighting EscherPro MR16 Spotlight- AAL-1019-4-B-BZ

Product Description

The EscherPro is AMP's first estate size spotlight. This durable fixture has one of the largest knuckles in the industry. With forty-two interlocking teeth that hold the fixture's precision aim, the fixture will never flop or adjust over time. This spotlight has a unique linear design for a look all it's own. It features a twist and lock faceplate for easy bulb installation, as well as a fully adjustable glare guard with the same look and shape of the fixture. This design allows water to drain from the lens with ease. It also features an inner pressure fit body to knuckle gasket for superior water protection along with an o-ring body gasket in the faceplate as well. As will all AMP[®] spotlights, it also has a silicone wire plug exit so water can't get in through the wire exit either. The EscherPro can take any of our MR16 bulbs making a tight fixture seam for superior heat dissipation. It also comes with a lifetime warranty.

Product Dimensions

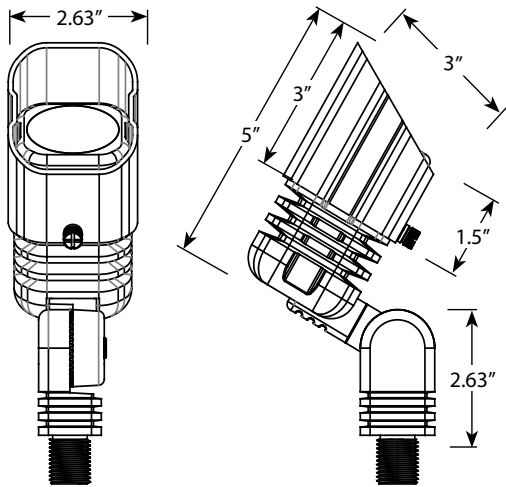

Specifications

- ▶ **Construction:** Brass
- ▶ **Mounting Orientation:** Uplight only
- ▶ **Finish:** Bronze
- ▶ **Lead Wire:** 18 AWG
- ▶ **Lens:** Clear Flat Glass
- ▶ **Light Source:** MR16 (sold separately)
- ▶ **Operating Voltage:** 12VAC
- ▶ **Powered by:** AMP's Low Voltage Transformer

Features & Benefits

- ▶ Estate Size Solid Cast Brass Construction.
- ▶ Pre-aged finish; natural patina that does not corrode.
- ▶ Beryllium copper socket more corrosion resistant than copper.
- ▶ Silicone wire plug in the bottom of the fixture.
- ▶ Twist and lock body design
- ▶ Strip resistant threading and solid brass locknut provide superior mounting stability.
- ▶ Fully adjustable knuckle with 42 interlocking teeth and adjustable glare guard allows light to be precision aimed.
- ▶ Tight bulb fitment that helps with heat dissipation.

Warranty

Lifetime Warranty

Certifications

