

PRODUCT SPECIFICATIONS

AMP[®]

Project Name _____ Date _____

Type or Model _____ Qty _____

AMP[®] Low Voltage Landscape Lighting TieredPro Path Light- AAR-3511-B-BZ

Product Description

The AMP[®] TieredPro Path Light has a classic Asian-inspired look with advanced features. The wider flanges result in less direct glare and better reflection down onto the surface of the ground. Corrosion-resistant internal components ensure years of optimal performance. The placement of the socket on the stem top makes inserting or changing bulbs fast and easy. Comes with a lifetime warranty.

Product Dimensions

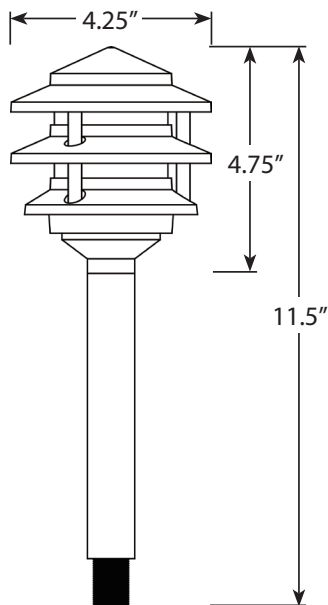

Features & Benefits

- ▶ Solid Brass construction
- ▶ Pre-aged finish; natural patina that does not corrode.
- ▶ Stem is 1-inch thick and includes extra-long (1-inch) strip resistant threading for greater stability.
- ▶ Beryllium copper socket - more corrosion resistant than copper.
- ▶ Silicone plug at lead wire exit prevents ground moisture and insects from entering luminaire through the stem.



Specifications

- ▶ **Construction:** Brass
- ▶ **Finish:** Bronze
- ▶ **Lead Wire:** 4' (standard) or 25' (optional) 16AWG
- ▶ **Mounting:** 10" Hammer[®] Stake with cutout for wire exit or brass Surface Mount
- ▶ **Lens:** Frosted Polycarbonate Lens
- ▶ **Light Source (not included):** Bipin (LED or Halogen)
- ▶ **Operating Voltage:** 12VAC
- ▶ **Powered by:** AMP's Low Voltage Transformer

Warranty

Lifetime Warranty

Certifications

