

PRODUCT SPECIFICATIONS



Project Name _____ Date _____

Type or Model _____ Qty _____

AMP® Low Voltage Landscape Lighting

AMP® LED Brass Flood Light with Yoke Mount- VFL-40XX-B-BZ

Product Description

The industry's first brass series of commercial style low-voltage LED flood lights. Compared to traditional aluminum flood lights, AMP's brass flood lights allow for much slimmer body designs while still offering high lumen outputs and ultra-wide beam angles. Ideal for expansive areas, large features, and up-lighting tree canopies. The fixtures feature powerful, efficient integrated LED light sources. Super-durable solid brass constructions with beautiful bronze finish to blend into any landscape. Tempered glass lenses are fully sealed with long-life gaskets to provide a tight fit against moisture intrusion. Frosted lenses create balanced blending of light outputs and offer added glare protection. Backed by a Lifetime Warranty.

Product Dimensions

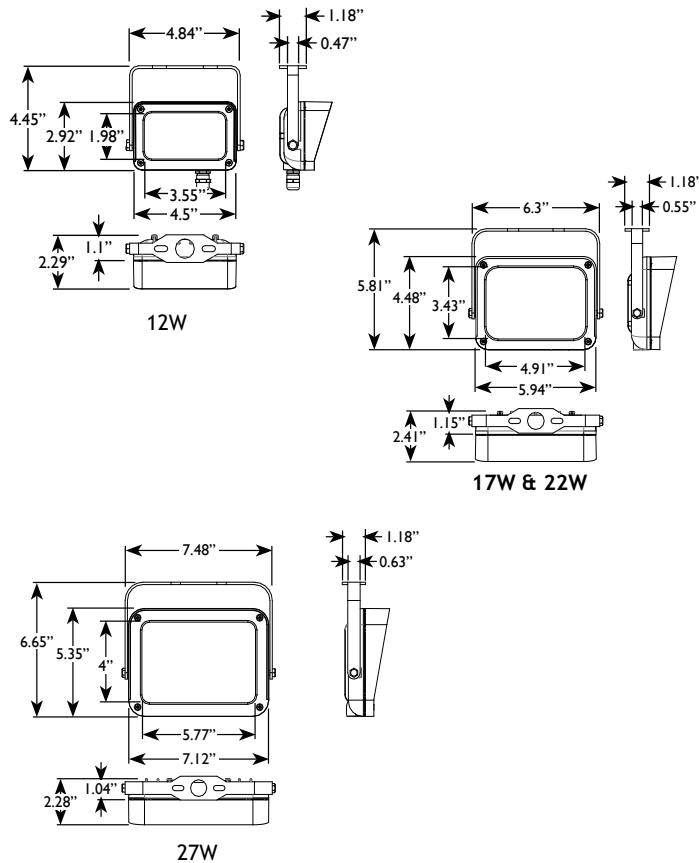

Features & Benefits

- ▶ Solid Brass Construction
- ▶ Pre-aged finish- a natural patina that does not corrode
- ▶ Multiple mounting options.
- ▶ Tempered glass lens is fully gasketed, to provide a tight fit against moisture.
- ▶ Sleek Design with built in heat sink for better thermal management.
- ▶ Instant illumination.

Specifications

- ▶ **Construction:** Brass
- ▶ **Finish:** Bronze
- ▶ **Mounting:** Yoke Mount
- ▶ **Light Source:** Integrated LED
- ▶ **Operating Voltage:** 12 VAC
- ▶ **Color Temperature:** 3000K
- ▶ **CRI:** >82
- ▶ **Lifetime:** 40,000 hours
- ▶ **Lumens:** 12W: 1000, 17W: 1500, 22W: 2000, 27w: 2500
- ▶ **Watts:** 12w, 17w, 22w, 27w
- ▶ **Powered by:** AMP's low voltage transformers

Warranty

Lifetime Warranty

Certifications



File #E466348



File #E466348