



# AMP® Low Voltage Landscape Lighting

## AMP® PuckPro Bi-Pin LED Hardscape Light - AHS-700X-0-B-RB

### Product Description

The AMP® Bi-Pin Puck Lights are designed for specific use with AMP®'s estate hanging light ONLY. The Bi-Pin design allows for an easy, on the spot replacement. Constructed of a round brass disc with a Cree® LED and AMP®-engineered driver embedded in waterproof epoxy. Simple to install; simply remove the current bi-pin puck light from the socket and drop in the replacement . With an estimated life of 40,000 hours and extremely low energy consumption, this solid brass LED light is an energy-efficient lighting powerhouse in a very small package. Backed by a Lifetime Warranty.

NOTE: These replaceable Bi-Pin puck lights are not designed for use in any fixture oriented upwards that is not sealed against moisture.



### Product Dimensions

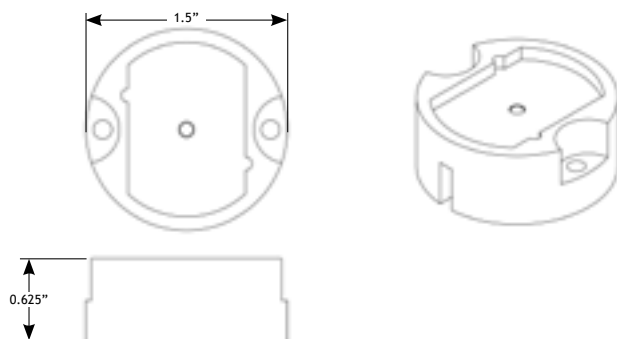

### Features & Benefits

- ▶ Solid Brass Construction
- ▶ High quality CREE® LED with AMP® engineered driver
- ▶ Embedded in water resistant epoxy

### Specifications

- ▶ **Construction:** Brass
- ▶ **Finish:** Raw Brass
- ▶ **Light Source:** Integrated LED
- ▶ **Color Temperature:** 2700K and 2200K
- ▶ **CRI:** 80+
- ▶ **Operating Voltage:** 6-18 VAC, with decreased lumens under 9V
- ▶ **Wattage:** 1W
- ▶ **Lumens:** 100
- ▶ **Lumen Maintenance:** 40,000 hours L70
- ▶ **Powered by:** AMP® Low Voltage Transformers

### Warranty

Residential: Lifetime Warranty  
Commercial: 10-Year Warranty

### Certifications



File #E366121



File #E366121