



# AMP® Solar Landscape Lighting

## AMP® Solarium Brass Solar LED Deck Light- ASDL-2014-B-BZ

### Product Description

The AMP® Solarium Brass LED Deck Light revolutionizes the way you will view solar products. With a full solar charge, this fixture offers 30 lumens of subtle, balanced illumination for several hours, then will gradually and subtly dim throughout the night before powering off for a total of 5-6 hours of use each night depending on the charge. Water-resistant features of the solar deck light include: sealed battery enclosure, potted socket, and pressure-fit gaskets in the body of the fixture. Premium quality components along with our lifetime warranty ensure this solar-powered fixture will last a lifetime.



### Product Dimensions

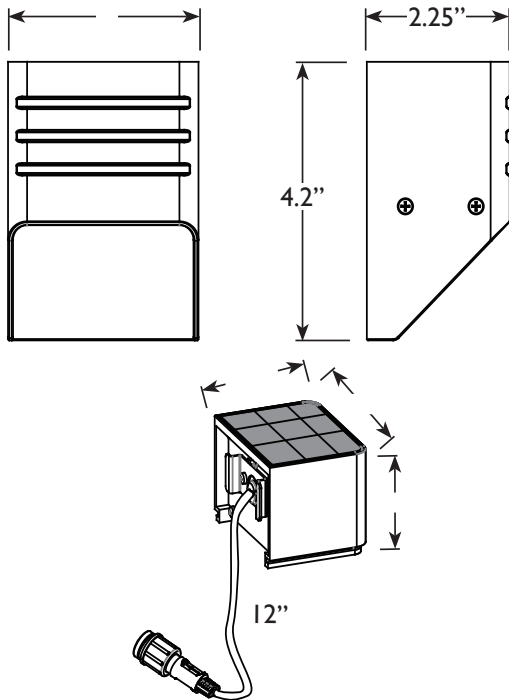

### Specifications

- ▶ **Construction:** Brass
- ▶ **Finish:** Bronze
- ▶ **Mounting:** Stainless steel bracket and screws
- ▶ **Light Output:** 30 lumens that gradually diminish as the batteries drain
- ▶ **Lens:** Clear Glass
- ▶ **Light Source:** Integrated LED
- ▶ **Charge Time:** 8 hours of uninterrupted sunlight for full battery charge
- ▶ **Battery Information:** 3pcs AAA Ni-MH rechargeable batteries with 500Mah, output 3.6v DC, 1.8Wh
- ▶ **Powered by:** AMP's attached solar panel

### Warranty

- Lifetime Warranty on fixture
- 2 Year Warranty on battery
- 2 Year Warranty on panel

### Features & Benefits

- ▶ Solid brass construction.
- ▶ Pre-aged finish; with a natural patina that does not corrode, or the option for a white powder coating.
- ▶ This deck light comes with a monocrystalline cell movable panel with an extra foot of wire to mount in a different location if better sun exposure is needed.
- ▶ Comes with water-tight gaskets to prevent water from entering the fixture. IP65 rated.