

## PRODUCT SPECIFICATIONS

# AMP<sup>®</sup>

Project Name \_\_\_\_\_ Date \_\_\_\_\_

Type or Model \_\_\_\_\_ Qty \_\_\_\_\_

## AMP<sup>®</sup> Solar Landscape Lighting AMP<sup>®</sup> Sol Box - ASDL-2014-P-BK

### Product Description

With a full solar charge, this fixture offers 30 lumens of subtle, balanced illumination for several hours, then will gradually and subtly dim throughout the night before powering off for a total of 5-6 hours of use each night depending on the charge. Water-resistant features of the solar deck light include: sealed battery enclosure, potted socket, and pressure-fit gaskets in the body of the fixture.

### Product Dimensions

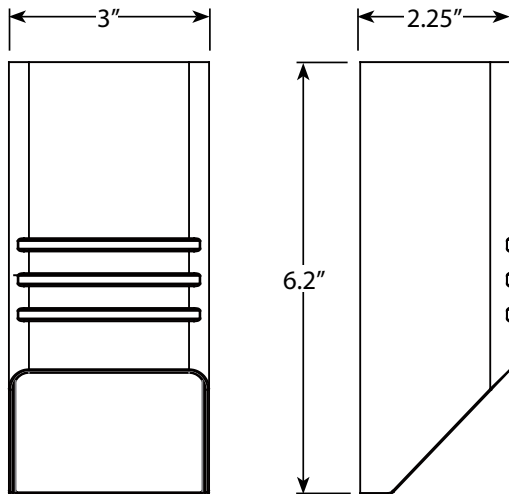

### Specifications

- **Construction:** Plastic
- **Finish:** Black
- **Mounting:** Stainless steel bracket and screws
- **Light Output:** 30 lumens that gradually diminish as the batteries drain
- **Lens:** Clear Glass
- **Light Source:** Integrated LED
- **Charge Time:** 8 hours of uninterrupted sunlight for full battery charge
- **Battery Information:** 3pcs AAA Ni-MH rechargeable batteries with 500Mah, output 3.6v DC, 1.8Wh
- **Powered by:** AMP's attached solar panel

### Features & Benefits

- Plastic black solar deck light made with an ABS material that is UV resistant.
- Monocrystalline cell solar panel.
- Comes with water-tight gaskets to prevent water from entering the fixture. IP65 rated.

### Warranty

2 Year Warranty