

PRODUCT SPECIFICATIONS

AMP[®]

Project Name _____ Date _____

Type or Model _____ Qty _____

AMP[®] Solar Landscape Lighting

AMP[®] Solar LED Deck Light (Black) - ASDL-2014-P-BK

Product Description

With a full solar charge, this fixture offers 30 lumens of subtle, balanced illumination for several hours, then will gradually and subtly dim throughout the night before powering off for a total of 5-6 hours of use each night depending on the charge. Water-resistant features of the solar deck light include: sealed battery enclosure, potted socket, and pressure-fit gaskets in the body of the fixture.

Product Dimensions

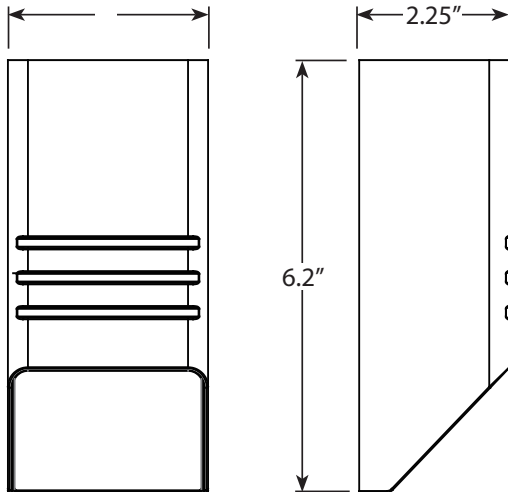

Specifications

- y **Construction:** Plastic
- y **Finish:** Black
- y **Mounting:** Stainless steel bracket and screws
- y **Light Output:** 30 lumens that gradually diminish as the batteries drain
- y **Lens:** Clear Glass
- y **Light Source:** Integrated LED
- y **Charge Time:** 8 hours of uninterrupted sunlight for full battery charge
- y **Battery Information:** 3pcs AAA Ni-MH rechargeable batteries with 500Mah, output 3.6v DC, 1.8Wh
- y **Powered by:** AMP's attached solar panel

Features & Benefits

- y Plastic black solar deck light made with an ABS material that is UV resistant.
- y Monocrystalline cell solar panel.
- y Comes with water-tight gaskets to prevent water from entering the fixture. IP65 rated.

Warranty

2 Year Warranty