

PRODUCT SPECIFICATIONS

AMP[®]

Project Name _____ Date _____

Type or Model _____ Qty _____

AMP[®] Solar Landscape Lighting

AMP[®] Solar LED Brass Dock Light- ASDL-2016-B-BZ

Product Description

With a full charge, this solar LED dock light offers approximately 25 lumens of warm, balanced illumination for dock or deck lighting applications. The light will gradually dim before powering off for a total of 10 hours of use each night depending on the charge. The battery requires 8-12 hours of uninterrupted sunlight to fully charge. Solid cast brass construction for a lifetime of durability. Quick and easy installation with mounting hardware included. Includes color filters options (amber, blue, and red). Transform your client's dock or deck while "Going Green" with professional quality solar powered landscape lighting.

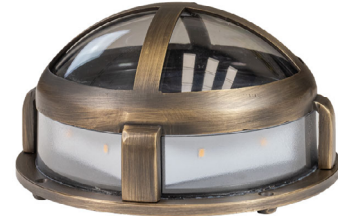

Product Dimensions

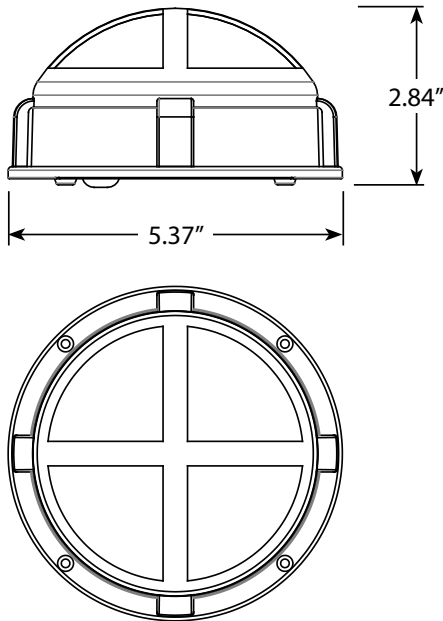

Specifications

- y **Construction:** Brass
- y **Finish:** Bronze
- y **Mounting:** Mounting hardware provided
- y **Light Output:** 25 lumens that gradually diminish as the batteries drain
- y **Lens:** Clear Glass
- y **Light Source:** Integrated LED
- y **Charge Time:** 8 hours of uninterrupted sunlight for full battery charge
- y **Battery Information:** Lithium rechargeable battery with 1200Mah, output 3.7v DC, 4.4Wh
- y **Powered by:** AMP's attached solar panel

Warranty

- Lifetime Warranty on fixture
- 2 Year Warranty on battery
- 2 Year Warranty on panel

Features & Benefits

- y Solid brass construction.
- y Pre-aged finish; with a natural patina that does not corrode, or the option for a white powder coating.
- y This dock light comes with 3 color filters (Amber, Blue, Red)
- y Triggers on at 30lux and off at 75lux with a buffer time of 5 seconds