

PRODUCT SPECIFICATIONS

AMP[®]

Project Name _____ Date _____

Type or Model _____ Qty _____

AMP[®] Solar Landscape Lighting AMP[®] Solar LED Path Light- ASPL-3028

Product Description

With a full charge, this solar LED path light offers 200 lumens of warm, balanced illumination for path and area lighting applications. The light will gradually dim before powering off for a total of 6 hours of use each night depending on the charge. The battery requires 8-12 hours of uninterrupted sunlight to fully charge. Quick and easy installation with multiple mounting options available. Transform your outdoor living spaces while "Going Green" with professional quality solar powered landscape lighting. Available in brass/bronze or plastic/black.

Product Dimensions

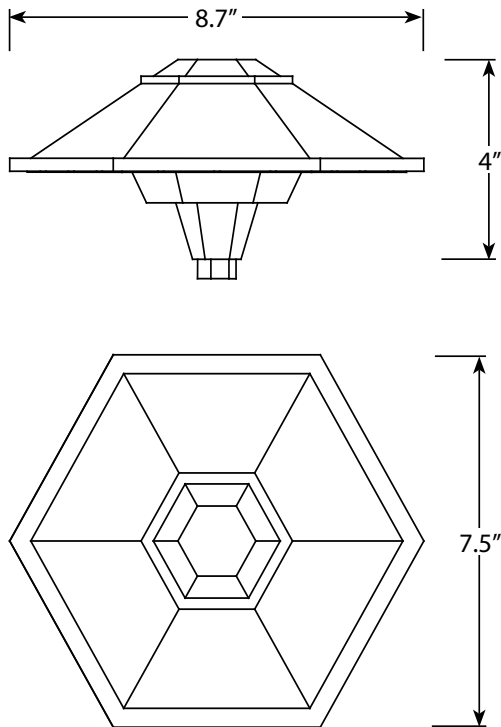

Specifications

- **Construction:** Brass or Black Plastic
- **Finish:** Bronze or Black
- **Light Output:** 200 lumens that gradually diminish as the batteries drain
- **Lens:** Frosted
- **Light Source:** Integrated LED
- **Charge Time:** 8-12 hours of uninterrupted sunlight for full battery charge
- **Battery Information:** Lithium rechargeable battery with 2600Mah; 3.7V
- **Powered by:** AMP's attached solar panel

Warranty

- Lifetime Warranty on brass fixture
- 2 Year Warranty on plastic fixture
- 2 Year Warranty on battery
- 2 Year Warranty on panel

Features & Benefits

- Available in brass bronze or black plastic
- Environmentally friendly with a professional quality solar panel
- IP 65 rating
- 2700K color temperature for a nice warm light
- Variety of different mounting options for a customizable install