

## PRODUCT SPECIFICATIONS

# AMP<sup>®</sup>

Project Name \_\_\_\_\_ Date \_\_\_\_\_

Type or Model \_\_\_\_\_ Qty \_\_\_\_\_

## AMP<sup>®</sup> Solar Landscape Lighting AMP<sup>®</sup> Solar LED Post-Top Light - ASPL-3029

### Product Description

With a full charge, this solar post-top fixture offers 50 lumens of subtle, balanced illumination for several hours, then will gradually and subtly dim throughout the night before powering off for a total of approximately 6-7 hours of use each night. Quick and easy installation with mounting hardware included. Designed for standard 4x4 posts. Transform your deck or patio while "Going Green" with solar powered lighting. Available in brass/bronze or plastic/black.



### Product Dimensions

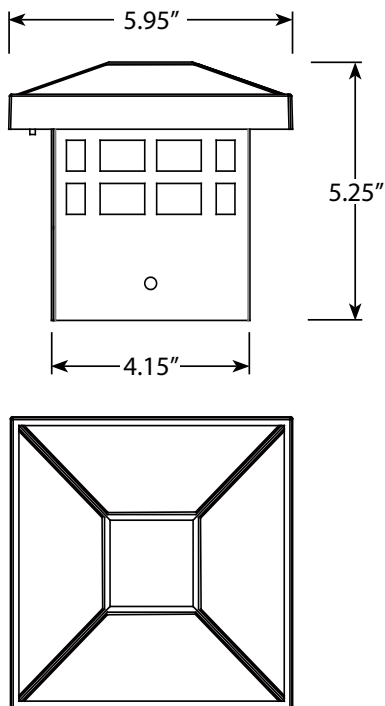

### Specifications

- y **Construction:** Brass or Plastic
- y **Finish:** Brass Bronze or Black Plastic
- y **Mounting:** 4x4 post
- y **Light Output:** 50 lumens that gradually diminish as the batteries drain
- y **Lens:** Clear Glass
- y **Light Source:** Integrated LED
- y **Charge Time:** 8-12 hours of uninterrupted sunlight for full battery charge
- y **Panel Size:** (4) 5.3" x 2.5"
- y **Powered by:** AMP's attached solar panel

### Warranty

- Brass Bronze Fixture- Lifetime Warranty
- Black Plastic- 2 Year Warranty
- Batteries- 2 Year Warranty

### Features & Benefits

- y With a full charge, this fixture will last 6-7 hours each night starting at 50 lumens and gradually diminishing from there.
- y Quick and easy installation on a 4x4 post.
- y Design creates pattern on the ground for extra aesthetic appeal.
- y Adds security and safety to decks, docks and fences
- y Available in brass/bronze or plastic/black.