



# AMP® Low Voltage Landscape Lighting AMP® MarinerPro LED Underwater Light

## Product Description

AMP®'s miniature underwater lights are designed for fast and easy installation. Non-skid rubber pads prevent the fixture from moving and allow for toolless installation (no drilling required). These low-profile fixtures are ideal for shallow water such as ponds and fountains (3" or more of water recommended). The fixture housings are constructed of solid cast brass with antique bronze finish for longevity and beauty. These are professional-quality fixtures with a hassle-free lifetime warranty.

## Product Dimensions

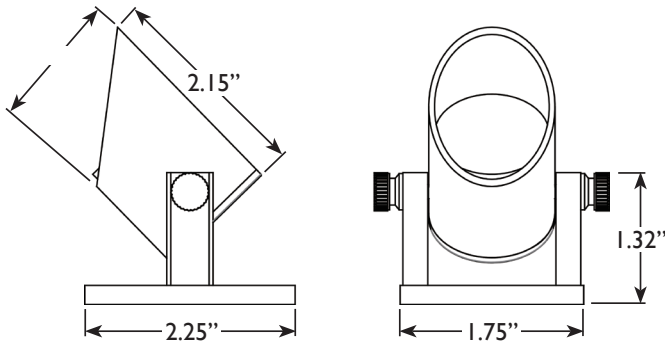

## Features & Benefits

- ▶ Cast brass construction with antique bronze finish for longevity and beauty.
- ▶ Non-skid rubber pads prevent fixtures from moving.
- ▶ May be installed in very shallow water (3" or more).
- ▶ Features an Integrated LED with a 100 lumen output and 2700K warm white color temperature.
- ▶ Fully brass fixture for underwater longevity. No plastic thumb screws that will break down over time.



## Specifications

- ▶ **Construction:** Brass
- ▶ **Finish:** Bronze
- ▶ **Lead Wire:** 25', 18AWG
- ▶ **Mounting:** Non-skid rubber pads prevent fixtures from moving
- ▶ **Lens:** Clear Flat Glass
- ▶ **Light Source:** Integrated LED
- ▶ **Operating Voltage:** 8-16 VAC
- ▶ **Powered by:** AMP's Low Voltage Transformer

## Warranty

Lifetime Warranty

## Certifications

