



AMP® HydraPro™ Shielded MR16 Brass In-Grade Light

Product Description

This redesigned in-grade light has several improved features. This fixture is made from cold forged brass, making it the ultimate underwater fixture. This version comes with a shielded top which provides added glare protection. In high foot traffic areas, or areas near the road it's better to use these to keep from blinding passerbys. It also has a pressure fit gasket that creates a tight seal keeping water out of the internal housing. Newly designed wire glands prevent water from getting into the fixture at one of the most common points of failure. This fixture can also be used on land with its efficient heat dissipation. Choose your desired lighting by selecting from our wide variety of MR16 bulbs.



Product Dimensions

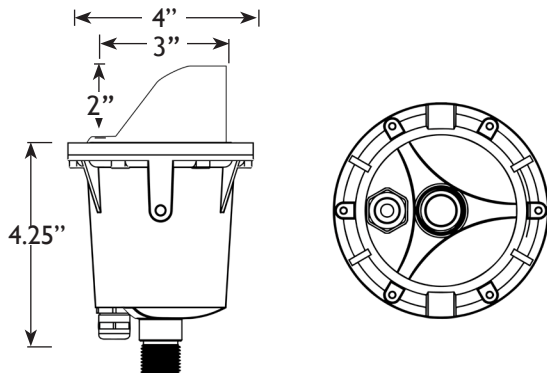

Specifications

- ▶ **Construction:** Cold Forged Brass
- ▶ **Finish:** Bronze
- ▶ **Lead Wire:** UL approved 18AWG, 2 conductor SJTW wire
- ▶ **Glass or Lens:** Clear Flat Glass
- ▶ **Light Source:** MR16
- ▶ **Operating Voltage:** 12V
- ▶ **Powered by:** AMP's Low Voltage Transformer
- ▶ **Torque Setting:** 1.5 ft. lbs.

Warranty

Lifetime Warranty

Features & Benefits

- ▶ Cold forged brass faceplate with pressure fit gasket (must be tightened in a star pattern) to guarantee complete waterproofing.
- ▶ Water tight wire glands ensure water cannot get inside the fixture.
- ▶ Lamp-ready for our wide array of MR16 lamps.
- ▶ Efficient heat dissipation.
- ▶ This fixture can be used fully submersed in water.
- ▶ Raised lens to prevent water from puddling.

Certifications



Specifications subject to change without notice.