



AMP® Low Voltage Landscape Lighting

EquaPro™ Wall Wash- AAL 1014

PRODUCT DESCRIPTION

Designed specifically for customers seeking modern aesthetics and unique lighting effects, the AMP® EquaPro Brass Black Wall Wash is a game-changer in the world of outdoor illumination. With its exceptional features and benefits, this wall wash light delivers a stunning lighting solution that goes beyond traditional spotlights. What sets the EquaPro Wall Wash apart is its ability to provide highly diffused, wide beam illumination without the typical cone-shaped patterns produced by traditional spotlights. The round shape and frosted lens work harmoniously to create an extra-wide beam with soft edges, delivering a beautiful and evenly distributed light that bathes your desired areas in a gentle, captivating glow.



PRODUCT DIMENSIONS

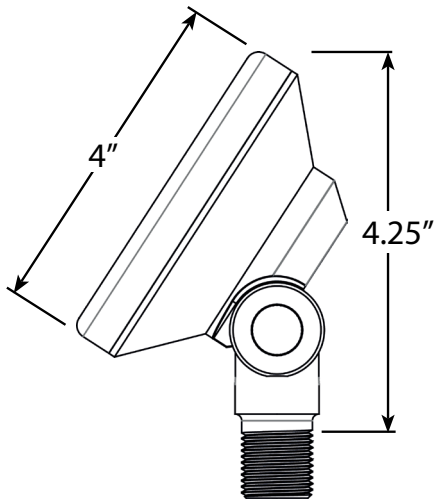

FEATURES & BENEFITS

- ▶ Cast Brass Construction.
- ▶ Beryllium copper socket – more corrosion resistant than copper.
- ▶ Silicone plug at lead wire exit prevents ground moisture and insects from entering luminaire through the stem.
- ▶ Adjustable knuckle for aiming the light exactly where you need to.
- ▶ Machine threaded body screws tight onto an O-ring for a moisture tight design.

SPECIFICATIONS

- ▶ **Construction:** Brass
- ▶ **Finish:** Bronze
- ▶ **Lead Wire:** 18AWG
- ▶ **Mounting:** 10" Hammer® Stake with cutout for wire exit
- ▶ **Lens:** Frosted lens for spread diffusion
- ▶ **Light Source (not included):** Bipin (LED or Halogen)
- ▶ **Operating Voltage:** 12VAC
- ▶ **Powered by:** AMP's Low Voltage Transformer

WARRANTY

Lifetime Warranty

CERTIFICATIONS

