



AMP® Low Voltage Landscape Lighting

Nano LED Spotlight- AAL-1049

PRODUCT DESCRIPTION

Introducing the Nano LED Spotlight – AMP’s tiniest solid brass integrated LED spotlight. Measuring just under 3” in length and less than 1” in height, this spotlight delivers an incredible amount of illumination while effortlessly blending into any setting.

Designed for non-traditional landscape applications, this spotlight is perfect for high-rises, apartments, and planters. Featuring a solid brass construction and an IP65 rating to withstand dust and jetting water, the Nano spotlight is built for reliable and long-lasting performance.

PRODUCT DIMENSIONS

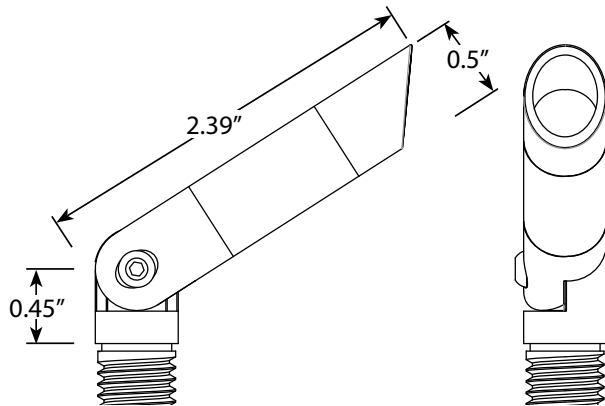

FEATURES & BENEFITS

- ▶ Sheet Brass Construction.
- ▶ Pre-aged finish; no powder coating, paint or finish to wear off or peel—just natural patina that does not corrode.
- ▶ Beryllium copper socket – more corrosion resistant than copper.
- ▶ Strip resistant threading provides superior mounting stability.
- ▶ Adjustable knuckle allows light to be precision aimed.



SPECIFICATIONS

- ▶ **Construction:** Brass
- ▶ **Finish:** Bronze
- ▶ **Lead Wire:** 18AWG
- ▶ **Lens:** Clear Flat Glass
- ▶ **Light Source (not included):** Integrated
- ▶ **Operating Voltage:** 12VAC
- ▶ Powered by: AMP’s Low Voltage Transformer
- ▶ **Lumens:** 85lm
- ▶ **Color Temperature:** 2700K

WARRANTY

Lifetime Warranty

CERTIFICATIONS

