



AMP® Low Voltage Landscape Lighting

G2 EcoPro Stainless Steel Spotlight - AAL-1052

PRODUCT DESCRIPTION

Featuring modern stainless steel and a compact and discreet design, the 2nd generation of our EcoPro spotlight allows for effortless concealment within any landscape. Its secure design guarantees the MR16 lamp remains firmly in place, providing reliable illumination. With a moisture-tight design, this fixture thrives in various environments. Tool-less knuckle allows for effortless adjustability and precision aiming. Built-in glare guard for directional glare control.

PRODUCT DIMENSIONS

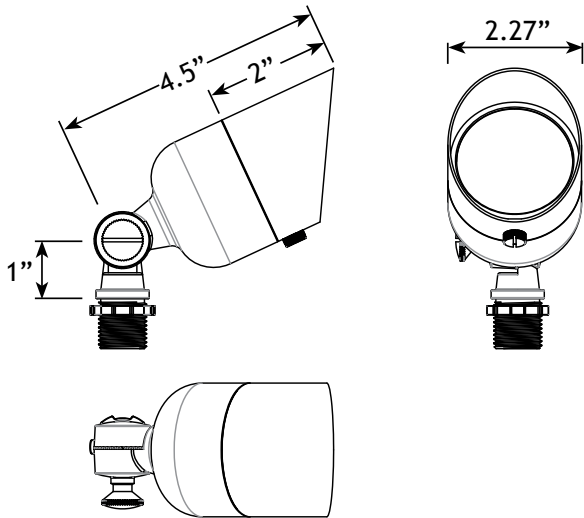

SPECIFICATIONS

- ▶ **Construction:** 316 Stainless Steel
- ▶ **Lead Wire:** 18 AWG
- ▶ **Mounting:** 10" Hammer® Stake with cutout for wire exit
- ▶ **Lens:** Clear Flat Glass
- ▶ **Light Source (not included):** MR16 (LED or Halogen)
- ▶ **Operating Voltage:** 12VAC
- ▶ **Powered by:** AMP's Low Voltage Transformer

WARRANTY

Lifetime Warranty

CERTIFICATIONS

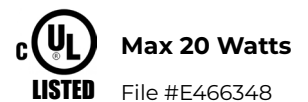
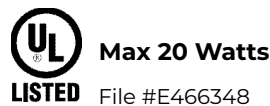

FEATURES & BENEFITS

- ▶ Rust resistant 316 Stainless Steel
- ▶ Beryllium copper socket – more corrosion resistant than copper.
- ▶ Silicone plug at lead wire exit prevents ground moisture and insects from entering luminaire through the stem.
- ▶ Water Tight Silicone O-Ring - keeps water from entering luminaire.
- ▶ Extra-long (1-inch) strip resistant threading and solid brass locknut provide superior mounting stability.
- ▶ Glare guard and heavy duty adjustable knuckle - allows light to be positioned.