



VOLT® LED Lamps

Red Turtle Safe LED Bi-Pin Series

Product Description

VOLT® Red LED Bi-Pins are designed to match the form factor and illumination of the incandescent bulbs they replace. We have created these to counteract the effects of light pollution near beaches causing turtles to come inland where oftentimes they perish. Instead; with turtle safe lights, the turtles will safely return to the ocean where they belong.

These lamps are instant-on. They are within the required nanometer range of 615-630 to protect the sea turtles for which they are designed. This wavelength of light provides adequate lighting for humans while remaining virtually invisible to the turtles. Each lamp has an estimated life of 40,000 Hrs.

Lifetime Replacement Warranty (for residential applications); the warranty for commercial projects is 10 years.

Product Dimensions

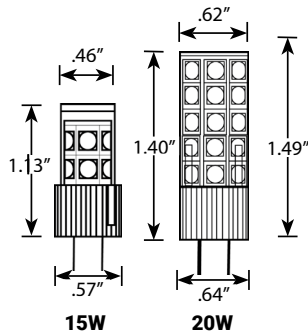

Features & Benefits

- ▶ Replacements for:
 - 15W and 20W Halogen Bi-Pins
 - Omni Directional beam angles
- ▶ Reduces energy consumption by about 75%
- ▶ Lasts up to 8 times longer than halogen lamps
- ▶ No warm-up time, instant-on with full light output and stable lamp to lamp color
- ▶ Suitable for use in enclosed fixtures



Specifications

- ▶ **Input Voltage, Frequency:** 11-21V, 50/60Hz AC- Will operate from 6-21V with decreased lumen output below 11V.
- ▶ **Input Power and Current:**
 - 2W (15W equiv.) Models: 177mA
 - 3W (20W equiv.) Models: 254mA
- ▶ **Power Factor:** 0.57 - 0.60
- ▶ **Beam Angles:** Omni-Directional
- ▶ **Color:** Red
- ▶ **Life:** 40,000 hours (L70)
- ▶ **Nanometer Range:** 615-630

Warranty

Residential: Lifetime Warranty
Commercial: 10-Year Warranty

Certifications

MUST BE INSTALLED IN A LOW MOUNTED, DOWNWARD DIRECTED AND SHIELDED FIXTURE.